

KEPCO

MPS

MULTIPLE OUTPUT POWER SUPPLY

Model MPS 620M

Serial No.

instruction manual

The KEPCO equipment described in this instruction manual is of proprietary design, and is licensed under the United States patent rights of Forbro Design Corp.

The contents of this instruction manual are copyrighted. Reproduction of any part may only be made with the specific written permission of KEPCO, Inc. Data subject to change without notice.



KEPCO®

© 1976, Kepco, Inc.

TABLE OF CONTENTS

PARAGRAPH		PAGE
SECTION I – INTRODUCTION		
1-1	Scope of Manual	1-1
1-3	General Description	1-1
1-6	Specifications, General	1-1
1-7	Specifications, 6V-5A Section	1-2
1-8	Specifications, (\pm)20V-1A Section	1-2
SECTION II – INSTALLATION		
2-1	Unpacking and Inspection	2-1
2-3	Terminations	2-1
2-4	A-C Input Voltage Conversion	2-3
2-6	Cooling	2-3
2-8	Preliminary Check-Out	2-3
2-10	Crowbar Check	2-4
2-11	Installation	2-4
SECTION III – OPERATION		
3-1	General	3-1
3-3	Safety Grounding	3-1
3-6	Signal Grounding	3-1
3-10	Power Supply/Load Interface	3-2
3-14	Load Wire Selection	3-2
3-16	Load Connection (\pm)20V-1A Supply	3-3
3-18	Load Connection, 6V, 5A Supply	3-4
SECTION IV – THEORY OF OPERATION		
4-1	Simplified Diagram Discussion	4-1
4-10	Circuit Description	4-2
SECTION V – MAINTENANCE		
5-1	General	5-1
5-4	Disassembly	5-1
5-5	Adjustment of the Internal Current Limit	5-2
5-7	Trouble Shooting	5-2
5-11	Power Supply Measurements	5-3

LIST OF ILLUSTRATIONS

FIGURE		PAGE
1-1	Kepeco Model MPS 620M, Multiple Output D-C Stabilized Power Supply, Front and Rear View	-iii/iv-
1-2	Mechanical Outline Drawing	1-3/1-4
2-1	Front Controls and Terminations, Model MPS 620M	2-1
2-2	Rear Terminations, Model MPS 620M	2-2
2-3	Location of the Internal Current Limit Control	2-2
2-4	Location of the A-C Source Selector	2-3
3-1	Typical Output Impedance vs. Frequency Plot for Stabilized D-C Voltage Sources	3-2
3-2	Load Connections, (\pm)20V-1A Supply	3-3
3-3	Load Connections, 6V-5A Supply	3-4
4-1	Simplified Schematic Diagram, Master/Slave D-C Source, (\pm)20V-1A Supply	4-4
4-2	Simplified Schematic Diagram, 6V-5A Supply	4-7/4-8
4-3	Simplified Schematic Diagram, (\pm)20V-1A Supply	4-9/4-10
5-1	Removing the Wrap-Around Cover and the Printed Circuit Boards from the Model MPS 620M	5-1
5-2	Connections for Output Effect Measurements	5-4
6-1	Plug-In Diagram, Model MPS 620M	6-19/6-20
6-2	Component Location, Main Chassis	6-21/6-22
6-3	Component Location, Assembly A1	6-23/6-24
6-4	Component Location, Assembly A3	6-25/6-26
6-5	Main Schematic Diagram, Model MPS 620M	6-27/6-28

LIST OF TABLES

TABLE		PAGE
1-1	D-C Output Effects vs. Change in Listed Influence Quantities	1-1
2-1	Front Panel Controls and Terminations	2-1
2-2	Rear Terminations	2-2
3-1	Internal Signal Ground Components	3-1

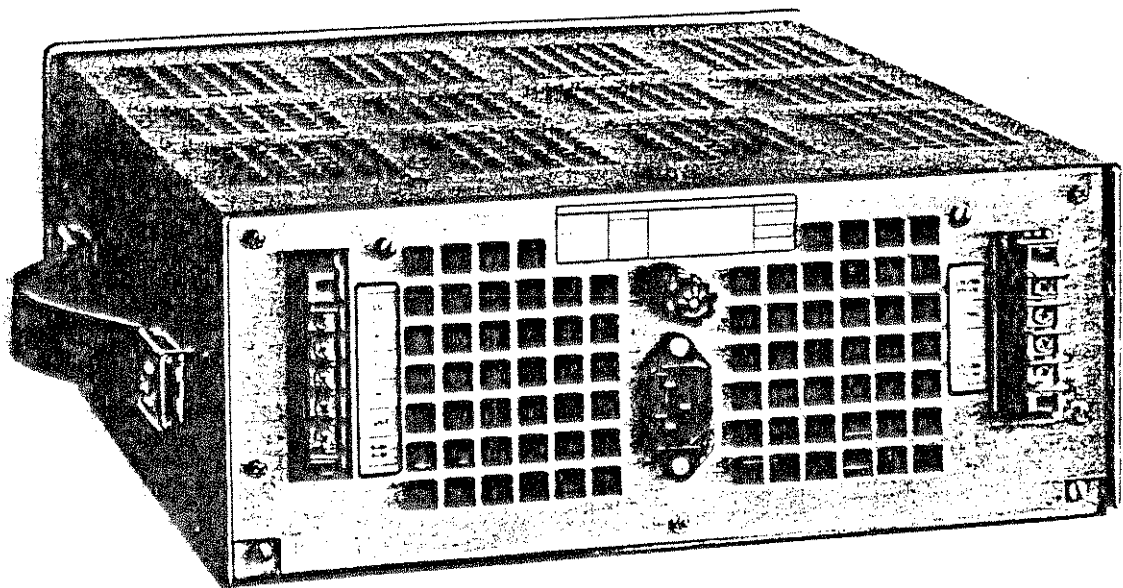
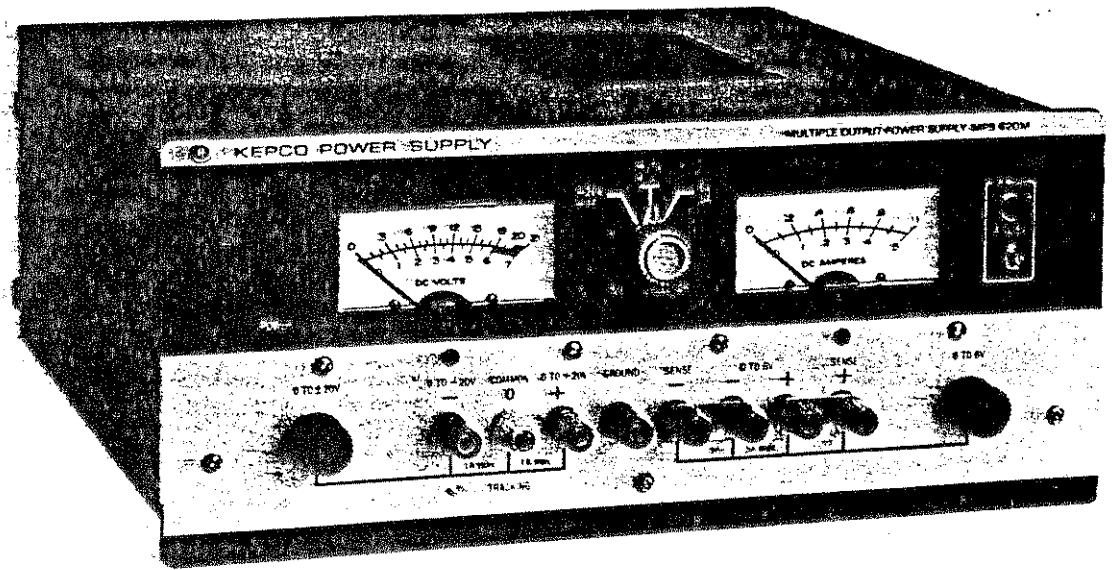

FIG. 1-1 KEPCO MODEL MPS 620M, MULTIPLE OUTPUT D-C POWER SUPPLY, FRONT AND REAR VIEW.

SECTION I—INTRODUCTION

1-1 SCOPE OF MANUAL

1-2 This manual contains instructions for the installation, operation and maintenance of the Model MPS 620M Multiple Output Power Supply, manufactured by Kepco Inc., Flushing, New York, U.S.A.

1-3 GENERAL DESCRIPTION

1-4 The Kepco Model MPS 620M is a multi-output, "bench-top" power supply, which provides the necessary voltage and current capability for the operation of most IC's and microprocessors. The Model MPS 620M consists of two main sections. The 6 volt, 5 ampere output section is equipped with an adjustable crowbar and crowbar light at the front panel and with remote error sensing terminals. The dual tracking ± 20 volt, 1 ampere section is equipped with adjustable current limiting. Both sections have precision 10-turn voltage controls at the front panel. The output voltage as well as the output currents are monitored by front panel voltage meters. Both outputs are completely short-circuit proof by virtue of an extremely sharp current limit characteristic. Both outputs are terminated at the front panel binding posts and at the barrier strip terminals at the rear of the power supply.

1-5 The Model MPS 620M is constructed in a three-quarter rack package. The chassis and wrap-around cover are made from cold-rolled steel, while the front panel material is aluminum. (Refer to the Mechanical Outline Drawing, FIG. 1-2)

1-6 SPECIFICATIONS, GENERAL

- a) A-C SOURCE POWER REQUIREMENTS: 105-125 a-c or 210 to 250V a-c, selectable by an internal a-c Source Selector (refer to Section II of this manual), 50 to 440 Hz, single phase, approximately 250W.
- b) D-C OUTPUT: See Table 1-1

INFLUENCE QUANTITY	OUTPUT EFFECTS		
	0 to 6V output	0 to $\pm 20V$ outputs	
SOURCE: 105-125/210-250V a-c, 50-440 Hz	0.01%	0.01%	
LOAD: No load - full load	0.01% ⁽¹⁾	0.05% ⁽¹⁾	
TIME: 8-hour drift	0.01%	0.01%	
TEMPERATURE: Per °C	0.01% ⁽¹⁾	0.01% ⁽¹⁾	
RIPPLE AND NOISE	rms	0.1 mV	0.1 mV
	p-p	1 mV	1 mV

⁽¹⁾ or 5 mv, whichever is greater.

TABLE 1-1 D-C OUTPUT EFFECTS vs. CHANGE IN LISTED INFLUENCE QUANTITIES.

- c) OPERATING TEMPERATURE: (-) 20°C to (+) 50°C Full output current at 50°C without derating.
- d) STORAGE TEMPERATURE: (-) 40°C to (+) 85°C.
- e) ISOLATION FROM GROUND: The circuit and output terminals have no d-c connection to ground and may be floated up to 300 volts (d-c or peak) off ground.
- f) VOLTAGE RECOVERY: The time required for the stabilized voltages to recover within 10 millivolts of the original voltage setting following a step in load current is less than 50 microseconds.
- g) SERIES/PARALLEL: The two (\pm) 20 volt outputs can be used in series to provide 0 to 40 volt at 1 ampere. They share a common (center) terminal and therefore cannot be used in parallel.
- h) METERS: Two recessed 2½" meters displaying voltage and current for all (3) outputs. Selected by a 3-position meter selector switch at the front panel.
- j) ACCESSORIES (NOT SUPPLIED): The Model MPS 620M can be rack-mounted, using the Kepco Model RA-24 Rack Adapter. The MPS occupies 3/4 of the adapter width. The remaining 1/4 width may be used to mount any Kepco "quarter rack" model, or may be filled using a Filler Panel, Kepco Model RFP 24-1.

7 SPECIFICATIONS, 6V, 5A SECTION

1-7

- a) OUTPUT VOLTAGE RANGE: 0 to 6 volts, continuously adjustable with ten-turn front panel control.
- b) CURRENT RATING: 0 to 5 amperes.
- c) REMOTE ERROR SENSING: Error sensing terminals (at the front panel, as well as in the rear) permit remote sensing at the load by means of a 4-terminal connection. Remote sensing compensates for static load wire voltage drops of up to 0.5 volt per lead. An additional 1 volt of output voltage (beyond the 6 volt rating) is provided for this purpose.
- d) CURRENT LIMITING: A fixed current limit is provided at approximately 110% (5.5A). The power section of MPS 620M has sufficient thermal capacity to maintain operation indefinitely into a dead short circuit. The output recovers automatically when the overload is relieved. The output locus is a rectangular characteristic, not a fold-back circuit.
- e) CROWBAR: The output is monitored by a front panel adjustable overvoltage crowbar circuit. The crowbar level can be set in the range from 4 to 8 volts. A crowbar indicator lamp is provided at the front panel.

8 SPECIFICATIONS, (\pm) 20V, 1A SECTION

1-4

- a) OUTPUT VOLTAGE RANGE (Two Outputs): 0 to (-) 20 volt and 0 to (+) 20 volt, simultaneously adjusted with a single, 10-turn front panel control. Tracking between outputs is better than $\pm 1\%$ + 10 mV.
- b) CURRENT RATING (EACH OUTPUT) 0 to 1 ampere.
- c) CURRENT LIMITING: The current limit point of both outputs can be pre-set with a simple internal control, in the range of 10 to 110% of the rated output current (0.1 to 1.1A). The power section of MPS 620M has sufficient thermal capacity to maintain operation indefinitely into a dead short circuit. The output recovers automatically when the overload is relieved. The output locus is a rectangular characteristic, not a fold-back circuit.

9 MECHANICAL SPECIFICATIONS:

1-

SEE "MECHANICAL OUTLINE DRAWING," FIG. 1-2.

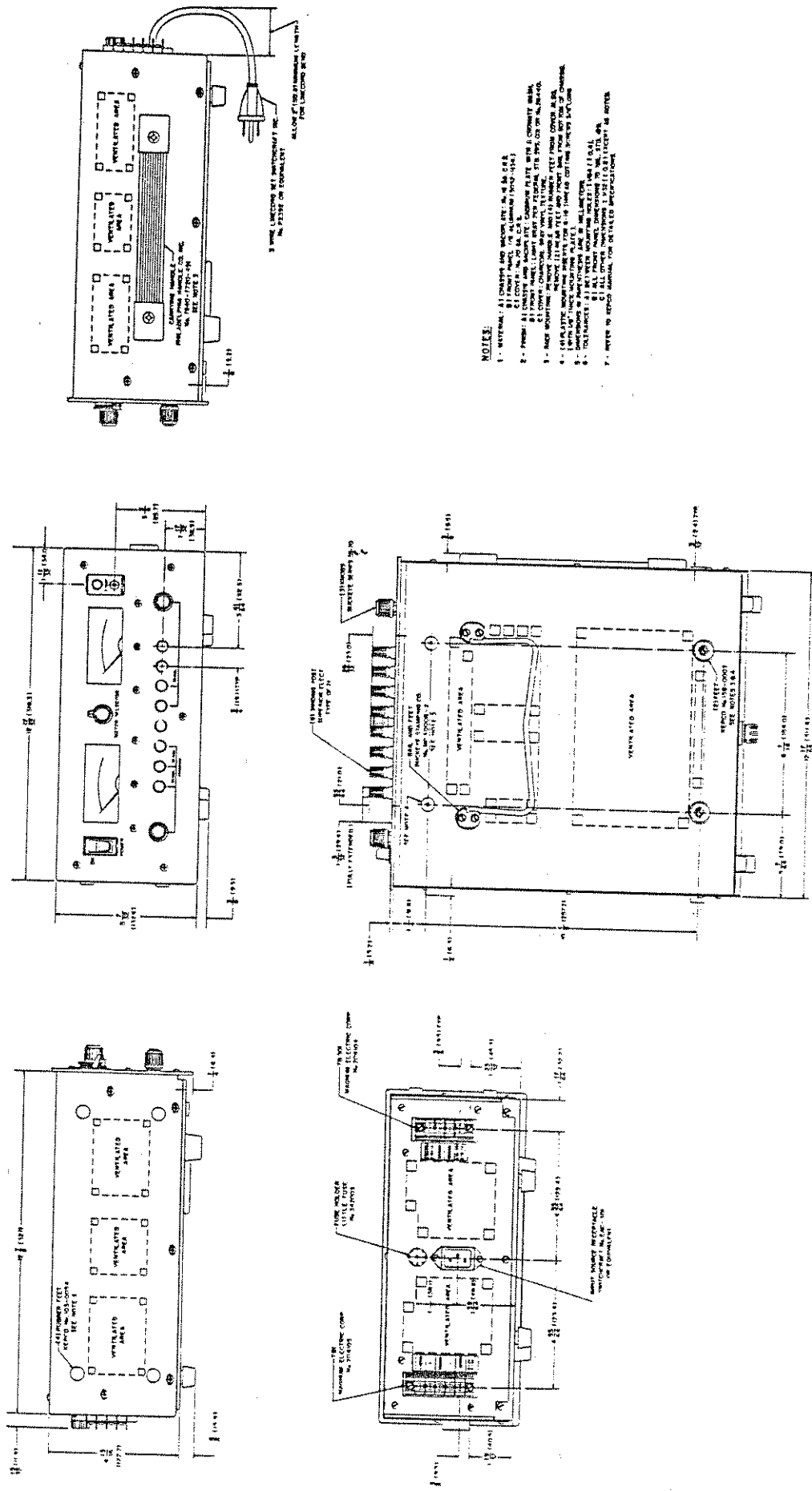

- NOTES:**
- 1 - INTERNAL: ALL DIMENSIONS AND WEIGHTS ARE IN INCHES AND POUNDS UNLESS OTHERWISE SPECIFIED.
 - 2 - FINISH: ALL SURFACES SHALL BE FINISHED TO THE FOLLOWING STANDARDS:
 - a) FLOOR: POLISHED CONCRETE OR POLISHED METAL.
 - b) WALLS: PLASTER OR GYPSUM BOARD WITH A FINISH OF WHITE ENAMEL OR PAINT.
 - c) CEILING: PLASTER OR GYPSUM BOARD WITH A FINISH OF WHITE ENAMEL OR PAINT.
 - 3 - ROOF: THE ROOF SHALL BE MADE OF CORRUGATED GALVANIZED IRON OR ALUMINUM WITH A FINISH OF WHITE ENAMEL OR PAINT.
 - 4 - LIGHTING: LIGHTING SHALL BE PROVIDED BY THE USER. THE USER SHALL PROVIDE A LIGHT SOURCE AND FIXTURES.
 - 5 - VENTILATION: THE VENTILATION SYSTEM SHALL BE PROVIDED BY THE USER. THE USER SHALL PROVIDE A SOURCE OF FRESH AIR AND A MEANS OF EXHAUSTING THE AIR.
 - 6 - ELECTRICAL: ALL ELECTRICAL CONNECTIONS SHALL BE MADE IN ACCORDANCE WITH THE NATIONAL ELECTRICAL CODE (NEC) AND ALL OTHER APPLICABLE ELECTRICAL CODES.
 - 7 - REFER TO THE USER MANUAL FOR DETAILED INFORMATION.

SECTION II – INSTALLATION

2-1 UNPACKING AND INSPECTION

2-2 This instrument has been thoroughly inspected and tested prior to packing and is ready for operation. After careful unpacking, inspect for shipping damage before attempting to operate. Perform the preliminary operational check as outlined in paragraph 2-8 below. If any indication of damage is found, file an immediate claim with the responsible transport service.

2-3 TERMINATIONS

a) FRONT PANEL: Refer to FIG. 2-1 and Table 2-1.

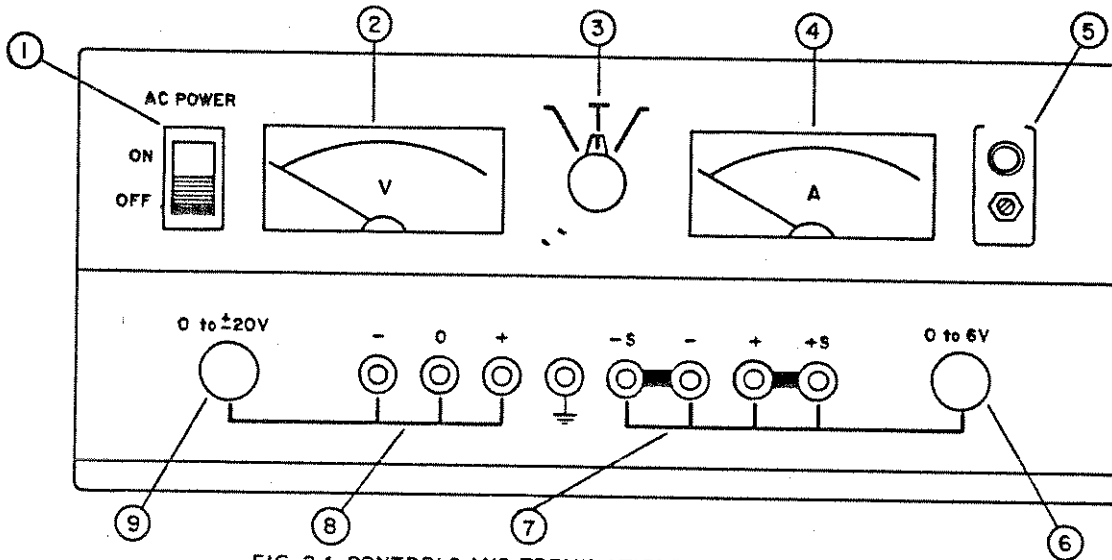

FIG. 2-1 CONTROLS AND TERMINATIONS, MODEL MPS 620M.

NO.	CONTROL OR TERMINATION	FUNCTION
1	A-C POWER SWITCH	A-C POWER LINE ON-OFF SWITCH, WITH "ON" LIGHT
2	VOLT METER	DISPLAYS EITHER 0 to 6V or 0 to ±20V OUTPUT VOLTAGE, DEPENDING ON METER SELECTOR POSITION.
3	METER SELECTOR	CONNECTS VOLTAGE AND AMMETER TO (-) 20V, 1A, (+) 20V, 1A or 6V, 5A RANGES.
4	AMMETER	DISPLAYS EITHER 0 to ±1A, OR 0 to 5A OUTPUT CURRENT, DEPENDING ON METER SELECTOR POSITION.
5	CROWBAR LEVEL CONTROL AND INDICATOR	SCREWDRIVER CROWBAR LEVEL ADJUSTMENT, 4 TO 8 VOLTS. CROWBAR INDICATOR, LIGHTS IF 6V SUPPLY IS CROWBARED.
6	VOLTAGE CONTROL (0-6V)	SETS OUTPUT VOLTAGE LEVEL, 6 VOLT SECTION.
7	OUTPUT AND SENSING	FRONT OUTPUT FOR 6V, 5A SECTION, SENSING TERMINALS LINKED TO OUTPUT TERMINALS.
8	OUTPUT TERMINALS	FRONT OUTPUT FOR ±20V, 1A SUPPLY
9	VOLTAGE CONTROL, 0 TO (±) 20V	SETS OUTPUT VOLTAGE LEVEL, (±) 20V SUPPLY.

TABLE 2-1 FRONT PANEL CONTROLS AND TERMINATIONS

b) REAR: Refer to FIG. 2-2 and Table 2-2.

NO.	TERMINATION	FUNCTION
1	REAR BARRIER STRIP, 6V-5A SUPPLY	DUPLICATES FRONT TERMINALS
2	A-C POWER INPUT CONNECTOR	NEMA/IEC CONNECTOR ACCEPTS LINE CORD (SUPPLIED)
3	FUSE	PROTECTS PRIMARY CIRCUITS
4	REAR BARRIER STRIP, (\pm)20V-1A SUPPLY	DUPLICATES FRONT TERMINALS

TABLE 2-2 REAR TERMINATIONS, MODEL MPS 620M.

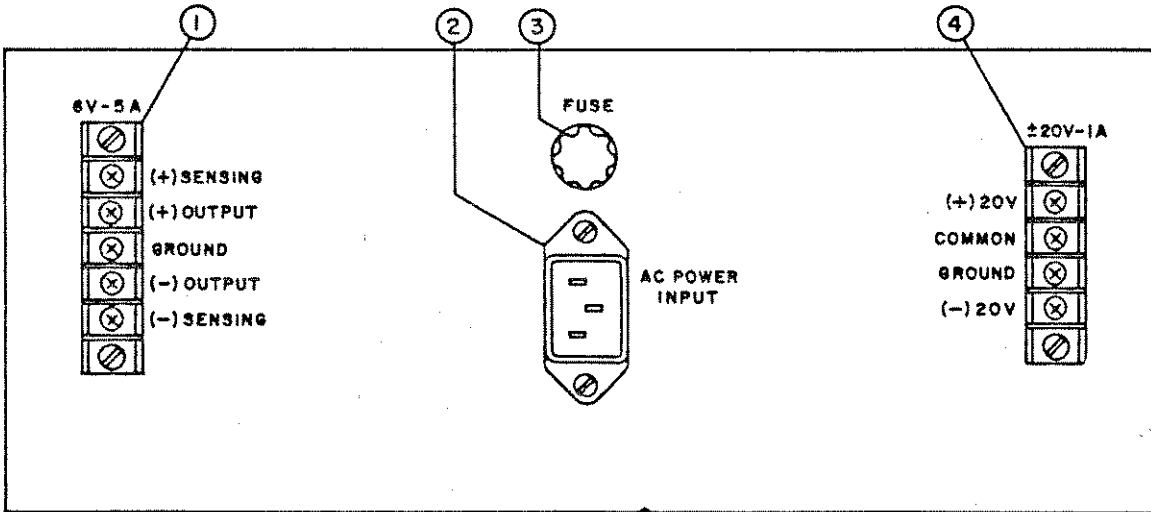

FIG. 2-2 REAR TERMINATIONS, MODEL MPS 620M.

c) INTERNAL CONTROL: See FIG. 2-3.

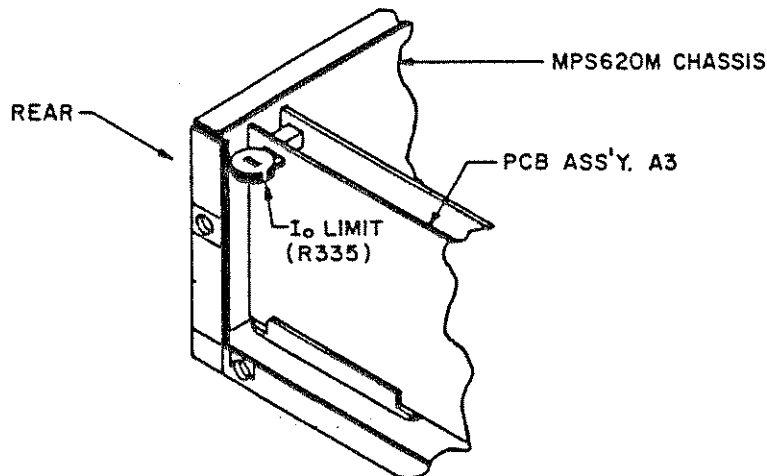

FIG. 2-3 LOCATION OF THE INTERNAL CURRENT LIMIT ADJUSTMENT FOR THE (\pm) 20V, 1A SUPPLY

2-4 A-C INPUT VOLTAGE CONVERSION.

- 2-5 This power supply is normally delivered for operation on a single phase, 115V a-c nominal a-c power line. For conversion to 230V a-c operation, set the A-C SOURCE SELECTOR (see FIG. 2-4) to the "230" position and change the fuse (see FIG. 2-2) to one half its former rating.

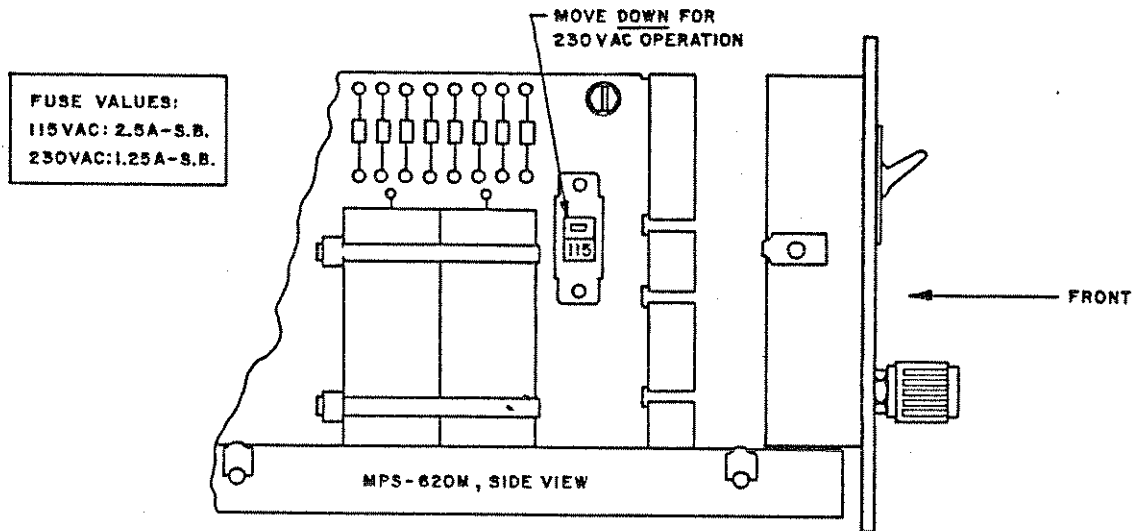

FIG. 2-4 LOCATION OF THE A-C SOURCE SELECTOR.

2-6 COOLING

- 2-7 Power dissipating components in the Model MPS 620M are cooled by convection. *Rear panel and cover openings must be kept clear from obstructions to insure proper air circulation.*

Periodic cleaning of the power supply interior is recommended. If the power supply is rack-mounted, or installed into other confined spaces, care must be taken that the temperature immediately surrounding the power supply does not rise beyond the specified maximum ambient operating temperature (50°C).

2-8 PRELIMINARY CHECK-OUT

- 2-9 A simple operating check after unpacking and before permanent installation is advisable to ascertain whether the power supply has suffered damage resulting from shipment. Refer to FIG. 2-1 and to FIG. 2-2 for the location of the operating controls and output terminals.
- Connect power supply to 115V a-c source, or refer to PAR. 2-4 for 230V a-c operation, if required.
 - Turn the A-C POWER switch of the Model MPS 620M "on." Set METER SELECTOR first to the "-20V/-1A" position. Turn the "0 TO $\pm 20V$ " front panel voltage control from fully counterclockwise to fully clockwise. The D-C VOLTMETER should indicate from the corresponding change from zero to approximately 20 volts.
 - Repeat with the METER SELECTOR in the "+20V/-1A" position.
 - Set METER SELECTOR to the "6V/5A" position. Turn the "0 to 6V" front panel voltage control from fully counterclockwise to fully clockwise. The D-C VOLTMETER should indicate the corresponding change from zero to approximately 6 volts. Turn the MODEL MPS 620M "off".
 - Connect a short length of wire between the (-) and (+) output terminals of both, the 0 to 6V-5A and the 0 to $\pm 20V$ -1A supply. Leave METER SELECTOR in the "6V/5A" position.
 - Turn Model MPS 620M "on". The short circuit current, as read out on the D-C AMPERE METER should be slightly more than 5A.
 - Turn METER SELECTOR to the "+20/+1A" and then to the "-20/-1A" positions. The D-C AMPERE METER should indicate a short circuit current slightly more than 1 ampere. Turn MPS 620M "off". Remove the wire jumpers from the output terminals.

10 CROWBAR CHECK:

- 1) Turn the MODEL MPS 620M "on" and set METER SELECTOR to the "6V/5A" position. Set the "0 to 6V" front panel voltage control for approximately 4V output.
- 2) With a screwdriver, turn the SET LEVEL crowbar control slowly counterclockwise until the CROWBAR light is "on". The front panel voltmeter should indicate a small *negative* output voltage.
- 3) *Back off* slightly on the "0 to 6V" voltage control and de-activate the overvoltage protector by momentarily turning the MPS 620M A-C POWER switch "off".
- 4) Turn MPS 620M A-C POWER switch "on" again. Slowly, turn the "0 to 6V" voltage control clockwise again and observe the crowbar level at the D-C VOLTMETER.

11 INSTALLATION (Refer to FIG. 1-2 "MECHANICAL OUTLINE DRAWING")

- 12 The MPS 620M power supply can be bench operated, or rack-mounted by means of the Kepco Model RA-24 Rack Adapter. If the MPS 620M is to be rack-mounted, the four (4) bottom feet and the front bail must be removed. Four (4) nylon mounting stand-offs are provided (two (2) of them are under the rear feet) which accept 8-18 thread-forming mounting screws. 2-
- 13 For installation into confined spaces, care must be taken that the temperature immediately surrounding the power supply does not exceed the maximum rated ambient temperature (50°C). 2-

SECTION III – OPERATION

3-1 GENERAL

- 3-2 Interconnections between an a-c power source and a stabilized power supply, and between the power supply and its load are as critical as the interface between any other electronic equipment. If optimum performance is expected, certain rules for the interconnection of source, power supply and load must be observed by the user. These rules are described in detail in the following paragraphs.

3-3 SAFETY GROUNDING

- 3-4 National and international safety rules dictate the grounding of the metal cover and case of any instrument connected to the a-c power source.

WARNING

KEEP INSTRUMENT GROUNDED WHILE IT IS CONNECTED TO THE A-C POWER SOURCE.

- 3-5 Kepco power supplies with flexible a-c power cord are equipped with a 3-prong safety plug, which must be connected to a grounded a-c power outlet.

3-6 SIGNAL GROUNDING

- 3-7 Connections between the power supply and the load (load and sensing connections), will invariably, despite all precautions such as shielding, twisting of wire-pairs, etc., "pick-up" radiated noise of a wide frequency spectrum. To minimize this undesired output, a SIGNAL GROUND is needed. The signal ground consists of a *single ground point*, either at one of the power supply output terminals or at one side of the load.
- 3-8 Kepco has provided an internal signal ground on both sections of the Model MPS 620M, consisting of a resistor/capacitor series combination from the output to the chassis. If, therefore, the chassis of the MPS 620M is a-c safety grounded by means of its three-prong plug, the safety, as well as the signal ground is automatically established.
- 3-9 The signal ground provided internally in the MPS 620M is sufficient for performance within specifications for most applications with an isolated load. If the load has its own ground, however, and high ripple is observed during operation, the internal signal ground in the MPS 620M may be removed by unsoldering the resistor associated with the signal ground.

DESIGNATION	SUPPLY	LOCATION	SECTION VI, FIG.
R46,	6V-5A	Assembly A1	6-3
R354,	±20V-1A	Assembly A3	6-4

TABLE 3-1 INTERNAL SIGNAL GROUND COMPONENTS

10 POWER SUPPLY/LOAD INTERFACE

- 11 The general function of a voltage or current stabilized power supply is to deliver the rated output quantities to the connected load. The load (or loads) may have any conceivable characteristic. It may be fixed or variable, it may have predominantly resistive, capacitive, or inductive parameters; and it may be located very close to the power supply, or it may be a considerable distance away. The power supply designer cannot anticipate every conceivable application, location or nature of the load. He must design his product for the widest possible application range and specify the performance at the output terminals of the power supply. The aim of the following paragraphs is to aid the user in the final use of the product: the interface of the power supply and the load.
- 12 The perfect interface between a power source and its load would mean that the specified performance at the output terminals would be transferred without impairment to any load, regardless of its characteristics, distance from the power supply or environment. To approach this ideal, the power supply must satisfy certain requirements, interconnecting rules must be closely followed and Ohm's Law, as well as basic a-c theory must be considered in selecting the interface wiring.
- 13 The stabilized d-c power supply is definitely not an ideal voltage or current source with zero output impedance (VOLTAGE MODE) at all frequencies. All voltage sources have some amount of impedance which increases with frequency. (Refer to FIG. 3-1). A more realistic model for a voltage stabilized power supply must, for example, include a series resistance, representing the small d-c and low frequency source impedance, in series with an inductance, representing the source impedance at higher frequencies.

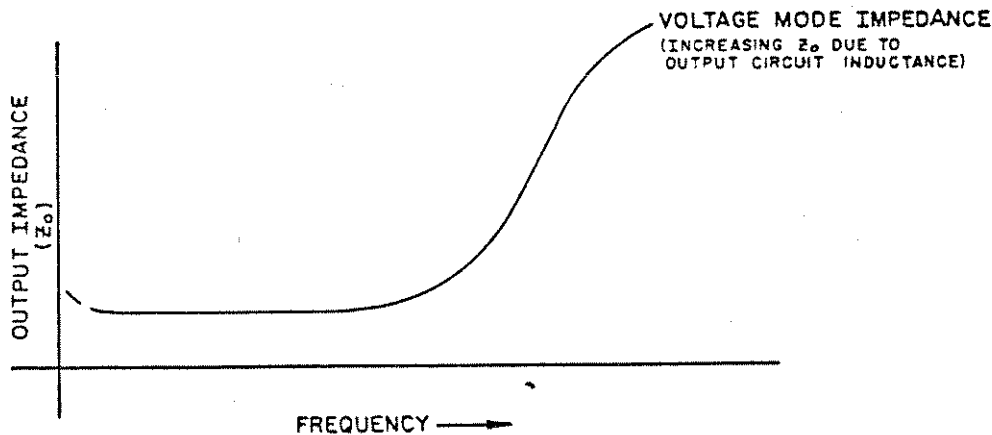

FIG. 3-1 TYPICAL OUTPUT IMPEDANCE VS. FREQUENCY PLOT FOR STABILIZED D-C VOLTAGE SOURCES.

14 LOAD WIRE SELECTION

- 15 Load wire selection should proceed considering the facts discussed in PAR's. 3-10 to 3-13. The load-wire size should not only be selected for minimum voltage drop, but also the series inductance of the load wire must be kept as small as possible compared to the source inductance of the power supply. These dynamic considerations are especially important if:
- 1) The load is constantly changing in value.
 - 2) The load is switched "on" and "off".
 - 3) The load has a primarily reactive characteristic.
 - 4) All other cases where the dynamic output response of the power supply is considered important.

IN PRACTICAL TERMS, THE LOAD WIRE SHOULD ALWAYS BE AS HEAVY AND AS SHORT AS POSSIBLE.

3-16 LOAD CONNECTION, (\pm) 20V - 1A SUPPLY (SEE FIG. 3-2)

3-17 For the low current (\pm) 20V supply, the interface with the load consists of a 2-wire connection from either the front, or the rear output terminals, The load wire should be selected as described (refer to PAR. 3-14) and should be tightly twisted to reduce "pick-up" from stray magnetic fields. After the grounding rules have been applied (refer to PAR's. 3-3 through 3-9, operation can begin.

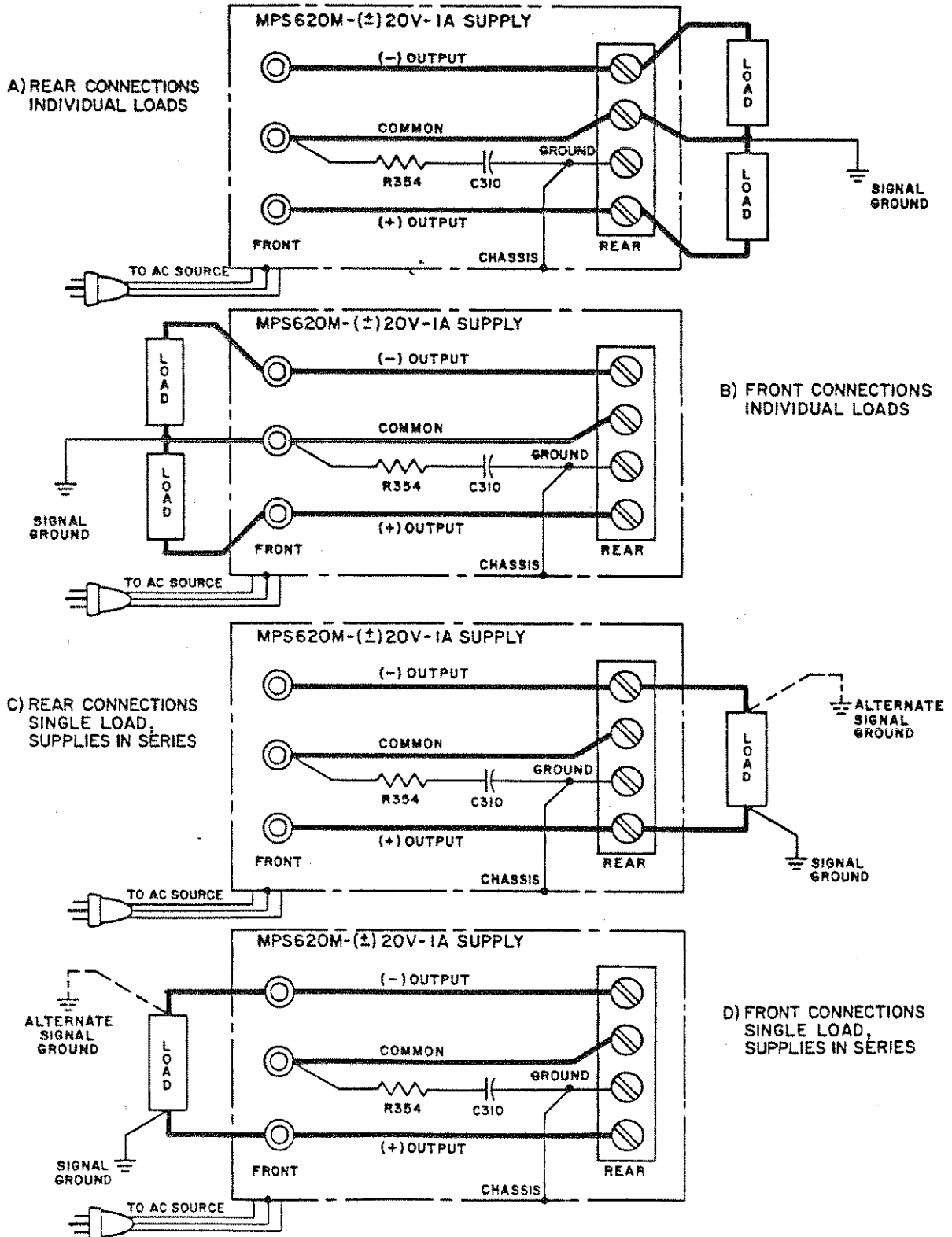

FIG. 3-2 LOAD CONNECTIONS, (\pm) 20V, 1A SUPPLY.

LOAD CONNECTION, (6V, 5A SUPPLY) (SEE FIG. 3-3).

The load may be connected in one of the ways illustrated in FIG. 3-3. **IMPORTANT NOTE: IF ERROR SENSING IS USED, THE SHORTING LINKS BETWEEN OUTPUT AND SENSING TERMINALS MUST BE COMPLETELY REMOVED. IF ERROR SENSING IS NOT USED, THE LINKS MUST BE CONNECTED AT THE FRONT, IF THE LOAD IS AT THE FRONT. THE LINKS MUST BE CONNECTED AT THE REAR, IF THE LOAD IS AT THE REAR.**

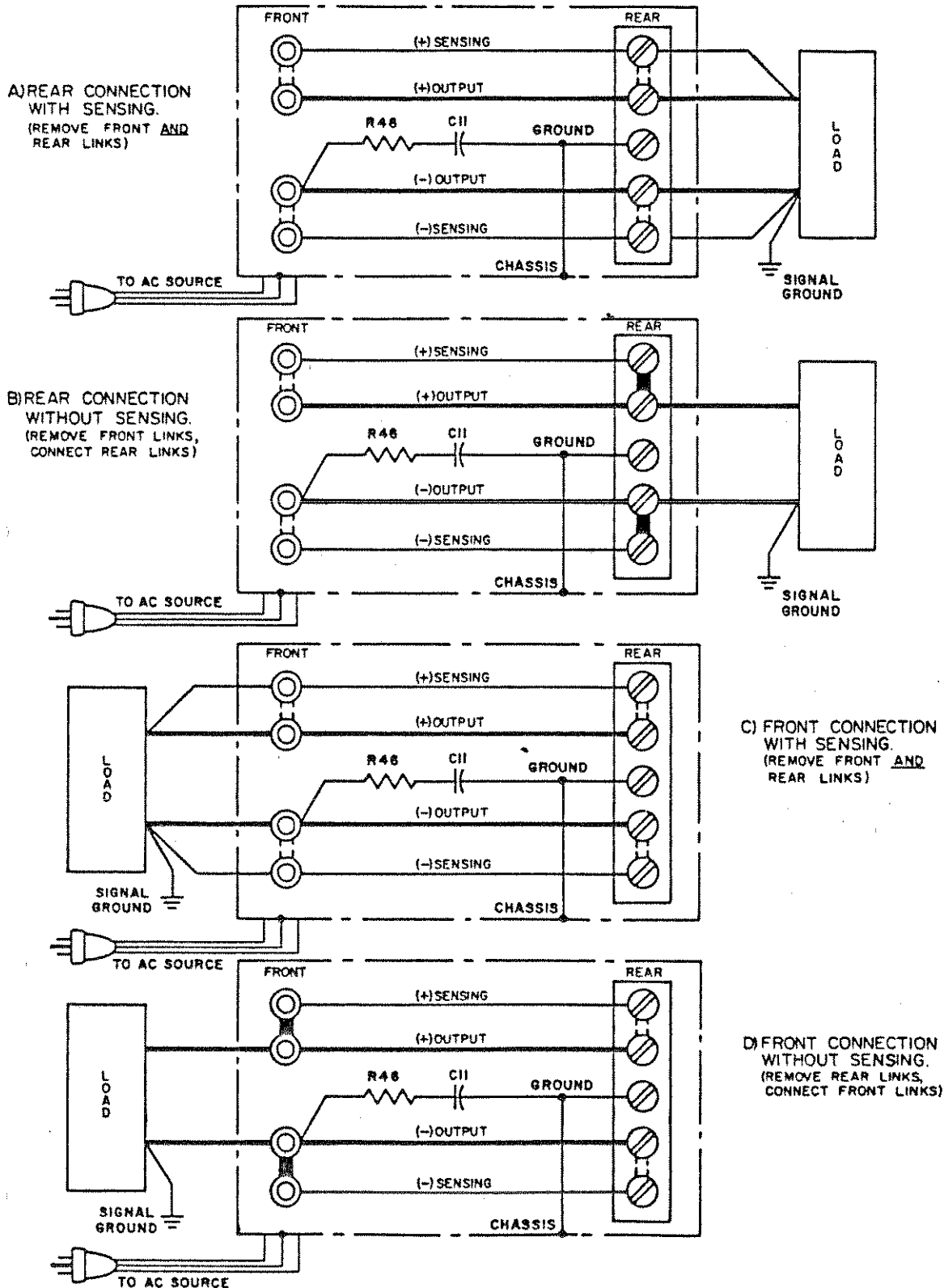

FIG. 3-3 LOAD CONNECTIONS, 6V, 5A SUPPLY.

SECTION IV – THEORY OF OPERATION

4-1 SIMPLIFIED DIAGRAM DISCUSSION

- 4-2 (6V, 5A SUPPLY, SEE FIG. 4-2). This is a 0 to 6V, 5A stabilized power supply with error-sensing, fixed current limiting and adjustable crowbar level. As seen from FIG. 4-2, the RAW D-C SOURCE is connected in series with the PASS TRANSISTOR, the current sensing resistor (R_g) and the external load across the (\pm) OUT terminals. The PASS TRANSISTOR changes its collector/emitter potential in response to the control signal received from the DRIVER stage, which in turn is controlled by a signal from the VOLTAGE MODE AMPLIFIER, the I_O LIMIT AMPLIFIER or the CROWBAR DETECTOR.
- 4-3 In the voltage mode of operation, the output voltage is continuously compared, by means of the VOLTAGE MODE AMPLIFIER, to a reference potential, established by the VOLTAGE CONTROL potentiometer across the internal reference source (E_{ref}). As long as the VOLTAGE MODE AMPLIFIER is in control of the PASS TRANSISTOR, its differential input voltage is practically zero and a state of balance exists. Any voltage variations, caused either by a change in load conditions, A-C input voltage or by a re-adjustment of the output voltage via the VOLTAGE CONTROL, produces an error signal at the input of the VOLTAGE MODE AMPLIFIER. The error signal is amplified and transmitted via the GATE diode to the DRIVER section, which alters the control signal to the PASS TRANSISTOR in such a way that the corresponding collector/emitter voltage change compensates to restore the previous balance conditions.
- 4-4 The I_O SENSING AMPLIFIER amplifies the voltage drop across the current sensing resistor (R_g). The amplified sensing voltage is compared with a reference voltage at the input of the I_O LIMIT AMPLIFIER. As long as the amplified sensing voltage stays below 5.4 volts (corresponding to an output current of 5.4 ampere), the circuit is inactive. If more output current is drawn, the gate diode for the I_O LIMIT AMPLIFIER conducts and the I_O LIMIT AMPLIFIER takes control of the PASS TRANSISTOR. In the I_O limit mode of operation, the output current will remain constant at 5.4A, while the output voltage will be reduced to a value depending on the load resistance.
- 4-5 The CROWBAR DETECTOR AMPLIFIER monitors the output voltage at the power supply's sensing terminals and compares a portion of the output at its (-) input to a reference potential, applied at the (+) input of the amplifier. As long as the output voltage remains below the reference level (which can be set by the CROWBAR LEVEL control) the circuit is inactive. If the output voltage exceeds the reference level, the CROWBAR DETECTOR AMPLIFIER conducts, fires the AUXILIARY S.C.R. and subsequently the MAIN CROWBAR. The AUXILIARY SCR removes the drive to the PASS TRANSISTOR and lights the front panel crowbar indicator, while the MAIN CROWBAR places a short-circuit across the output of the power supply. The crowbar circuit is de-activated by removing the cause of the overvoltage and by momentarily interrupting the a-c power to the power supply.
- 4-6 ($\pm 20V$, 1A SUPPLY, SEE FIG. 4-3). This is a (\pm) 20V, 1A stabilized dual tracking power supply in a master/slave configuration, with variable current limit. As seen from FIG. 4-3, the RAW D-C sources of the MASTER and the SLAVE sections are connected in series with their respective NPN and PNP PASS TRANSISTORS, their sensing resistors (R_{sm} and R_{ss}) and the external load across the output terminals. The PASS TRANSISTORS change their collector/emitter potentials in response to either their associated VOLTAGE MODE AMPLIFIERS or their I_O LIMIT AMPLIFIERS.
- 4-7 In the voltage mode of operation, a part of the output voltage is continuously compared, by means of the MASTER VOLTAGE MODE AMPLIFIER, to a reference potential, established by the VOLTAGE CONTROL potentiometer across the internal reference source (E_{ref}). As long as the MASTER VOLTAGE MODE AMPLIFIER is in control of the PASS TRANSISTOR (NPN), its differential input is practically zero and a state of balance exists. Any output voltage change, caused by change in load conditions, a-c input voltage variations or by a re-adjustment of the VOLTAGE CONTROL, produces an error signal at the differential input of the MASTER VOLTAGE MODE AMPLIFIER. This error signal is amplified and transmitted via the GATE diode and acts as a control signal for the PASS TRANSISTOR (NPN) which in response, alters its collector/emitter potential in such a way as to compensate for the initial output voltage change and restore the previous balanced condition.

The SLAVE VOLTAGE MODE AMPLIFIER is driven by the MASTER output voltage (E_{OM}) and establishes the SLAVE output voltage (E_{OS}) according to the transfer function: $E_{OS} = E_{OM} (R_i/R_f)$, where $R_i = R_f = 20 \text{ K}$. Since the ratio $R_i/R_f = 1$, the SLAVE output voltage follows that of the MASTER SUPPLY in the same (1:1) ratio.

4-8

The output current is sampled continuously by the current sensing resistors (R_{SM}, R_{SS}). The sample voltage is connected to the respective current limit amplifiers (I_O LIMIT AMP, MASTER and SLAVE) and is there compared to a reference potential. The reference potential is derived from the zener reference source (E_{ref}) and applied via the I_O LIMIT CONTROL to the I_O LIMIT AMP-SLAVE and via the REFERENCE INVERTER to the I_O LIMIT AMP-MASTER. The I_O LIMIT control can be set from approximately 0.1A to 1.1 amperes. As long as the reference potential at the input of both I_O LIMIT AMPLIFIERS is greater than the sampled voltage drop across the current sensing resistors (R_{SM}, R_{SS}) the circuit is inactive. If more output current is drawn, resulting in a sampling voltage greater than the reference potential, the I_O LIMIT AMPLIFIERS conduct and take control of their respective PASS TRANSISTORS. In the I_O Limit mode of operation, the output current will remain at the value set by the I_O LIMIT control, while the output voltage will be reduced to a value depending on the load resistance.

4-9

CIRCUIT DESCRIPTION

4-10

For the purpose of analysis, the circuitry of the MPS Power Supply may be divided into several sections which are individually described below. The main schematic (FIG. 6-5) should be used to illustrate the text of this section.

4-11

- a) A-C INPUT CIRCUIT. A-C line power is introduced through the (detachable) 3-wire line cord with safety plug. The use of a grounded a-c power outlet will automatically ground the power supply, since the third wire of the line cord is directly connected to the metal chassis and case. Once the a-c power switch/pilot light (SDS 101) is closed, the primary of the two transformers (T201, T202) will be energized. The dual primary windings of the transformers are either connected in parallel (for 115V a-c nominal line voltage) or in series (for 230V a-c nominal line voltage) by means of the a-c source selector (S301). The a-c input circuit is protected by a fuse (F201).
- b) MAIN D-C SUPPLY, (6V, 5A Section). The main d-c power is derived from a center-tapped secondary winding on T201. A full-wave rectifier circuit with silicon diodes CR201, CR202 (located on the heat sink assembly) works into a capacitor input filter (C202), paralleled by a bleeder resistor (R201). The main d-c supply delivers the output current through the series regulator or pass elements and serves as a collector supply for the main driver transistor (Q1).
- c) SERIES REGULATOR (PASS ELEMENTS 6V, 5A Section). The series regulator transistors (Q401, Q501) are NPN silicon devices, located on extruded heat sinks (A4, A5). Electrically, these pass transistors are connected in series with the (unregulated) main d-c supply and output. The effective series resistance of the pass transistors (and thereby the voltage drop across them) is changed in such a way as to keep the output voltage constant, regardless of variations in the unregulated main supply. The base drive needed to affect this change in the pass transistors is supplied by the main driver/pre-driver combination (Q1, Q2) located on the main amplifier assembly (A1).
- d) VOLTAGE CONTROL CIRCUIT (6V, 5A Section). The output voltage amplifier (E_O COMPARATOR-IC-2) compares the output voltage at the negative sensing terminal (TB1,-s) via R29, to a reference potential, derived from the center contact of the VOLTAGE CONTROL (R101). A state of equilibrium exists if the output voltage is equal to the reference potential and the input to the voltage amplifier (IC-2) is zero. The power supply is then operating in the voltage mode and IC-2 is in control of the pass elements (Q401, Q501). Any voltage variations, caused by a re-adjustment of the output voltage via R101, by a load change or by an a-c input voltage change, is interpreted by IC-2 as an error signal. The error signal is amplified and transmitted via the gate diode (CR13) to the driver section (Q1, Q2) which changes the drive to the pass transistors (Q401, Q501) and thereby the voltage drop across them is in such a way as to restore the previous equilibrium condition.

4-2

- e) CURRENT LIMIT CIRCUIT (6V, 5A, Section). The current limit circuit consists of the I_o SENSE AMPLIFIER (1/2 IC-1) and the I_o LIMIT AMPLIFIER (1/2 IC-1) with their associated components. The output current is sensed at the current sensing resistor (R24) and the voltage drop across R24 is applied to the differential input of the I_o SENSE AMPLIFIER, (which has a fixed gain of 10) and goes from its output to the non-inverting input of the I_o LIMIT AMPLIFIER where it is compared to a reference potential (derived via CR10, R20, R23). As long as the amplified voltage drop from the sensing resistor (R24) stays below approximately 5.4 volt (representing an output current of 5.4 ampere) the circuit is inactive. If more output current is drawn, the gate diode (CR9) connected to the output of the I_o LIMIT AMPLIFIER will conduct and the I_o LIMIT AMPLIFIER will control the pass elements. The power supply is then operating in the current limit mode, i.e., its output current will remain constant at the limiting value, while the output voltage will be reduced to a value which is proportional to the load resistance, e.g., for a short circuit, the output voltage will be zero.
- f) The CROWBAR CIRCUIT (6V, 5A Section). The CROWBAR DETECTOR AMPLIFIER (IC-3) monitors the output voltage at the power supply's sensing terminals (TB1, -s, +s) via resistors R37 and R38. It compares a portion of the output voltage at its inverting input to a reference potential (derived from CR10, R40) applied via the CROWBAR LEVEL control (R102) to its non-inverting input. As long as the output voltage sample stays below the reference voltage level (which can be set by the front panel CROWBAR LEVEL control in the range from approximately 2.75V to 6.2V) the circuit is inactive. If the output voltage sample should exceed the reference level, the CROWBAR DETECTOR amplifier (IC-3) starts to conduct. If the amplified signal is large enough to overcome the voltage drop across the barrier diode (CR16), the first SCR (CR47) is fired, turning on the transistor (Q4) and the CROWBAR light (DS101) and transmitting a turn-on pulse to the MAIN SCR (CR102). Simultaneously, Q5 is turned "on", pulling down the (-) input of the I_o LIMIT AMPLIFIER (1/2 IC-1) and thus limiting the output current to a small value. Due to the action of this turn-off circuit, the MAIN SCR (CR102) does not have to carry the short-circuit current. De-activation of the CROWBAR CIRCUIT requires removal of the a-c input power to the MPS 620M power supply.
- g) AUXILLIARY D-C SUPPLIES (6V, 5A Supply)
- 1) RETURN SUPPLY. This d-c voltage is derived from the same winding on T201 as the main 6 volt supply. Rectified by CR1 and CR2 and filtered by C1, the (-) d-c voltage is applied to the base of the pass transistors (Q501, Q601) via resistor R1, with reference to the (-) OUT terminal. The return supply has the function to insure the turn-off bias for the pass transistors under all operating conditions, especially at elevated operating temperature.
 - 2) PRE-DRIVER SUPPLY. This full-wave rectified (CR3) and capacitor filtered (C2) d-c source is derived from a secondary winding on T201. It delivers the collector voltage for the pre-driver stage (Q2) via decoupling resistor R6 and the operating voltage for the crowbar indicator stage (Q4). R7 is a bleeder resistor for C2, while R4 and R5 establish the bias conditions for the pre-driver and driver transistors (Q1, Q2).
 - 3) AMPLIFIER POWER SUPPLY. This d-c source is derived from a secondary winding on transformer T201. A bridge rectifier (CR4) and a capacitor filter (C3) provide the raw d-c voltage which is stabilized by two zener diodes (CR7, CR8), fed from a constant current stage (Q3, CR5 and associated components). This stabilized $\pm 12V$ d-c source provides the operating potential for the operational amplifiers (IC1, IC2, IC3). The (-)12 volt half of the dual source is used to establish the reference potential (CR10, via R18), while R17 loads the positive side to establish equal loading.
- h) MAIN D-C AND PASS TRANSISTOR SECTIONS ($\pm 20V$, 1A Supply). The main d-c supply is derived from two separate windings on transformer T202. Both, the negative (MASTER) and the positive (SLAVE) supplies are full-wave rectified (CR301 to CR304 and CR311 to CR314) as well as capacitor filtered (C301, C303).

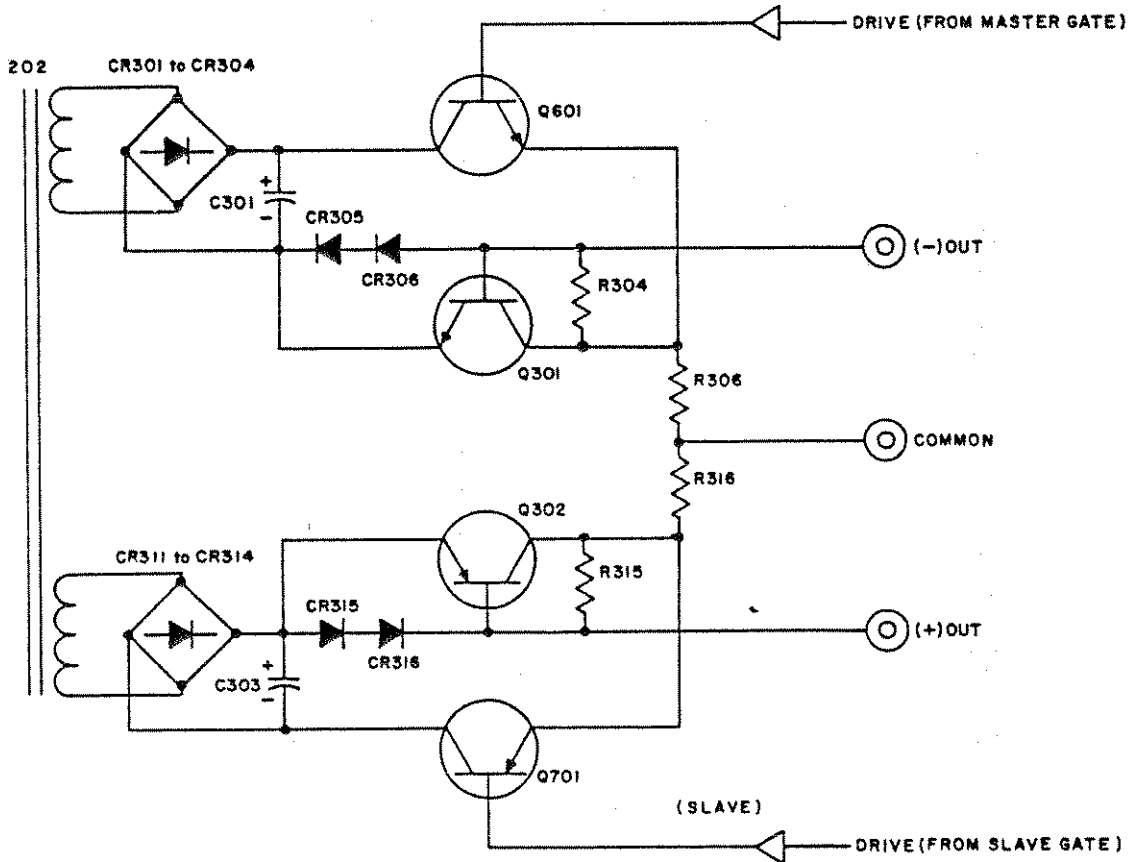

FIG. 4-1 SIMPLIFIED SCHEMATIC DIAGRAM, MASTER/SLAVE D-C SOURCE, $\pm 20V$ SUPPLY.

(Refer to FIG. 4-1). Both raw d-c voltage sources are connected in series with their respective pass transistor (Q601, Q701), their current sensing resistors (R306, R316), and their series diodes (CR305, CR306, CR315 and CR316). The output voltage, between COMMON and (-) OUT, (+) OUT respectively, is stabilized by the action of the series pass transistors (Q601, Q701), which change their collector/emitter potential in response to appropriate drive signals via the master and slave gates in such a way as to compensate for voltage variations at the output terminals. To achieve output control to zero volts, especially at elevated operating temperatures, each pass transistor is provided with a constant current source, consisting of transistors Q301 and Q303, with their associated resistors.

i) VOLTAGE CONTROL CIRCUIT ($\pm 20V$, 1 A Supply). A sample of the negative output voltage is applied via the voltage divider (R351, R352) to the non-inverting input of the E_0 MASTER voltage mode amplifier (IC303) and compared to a reference potential, applied at the inverting input of the same amplifier. The reference potential is derived via the VOLTAGE CONTROL (R103), connected across the REFERENCE zener diode (CR323). A state of equilibrium exists if the output voltage sample and the reference potential are equal. In this case, the differential input voltage to the E_0 MASTER amplifier is zero and the power supply is operating in the voltage mode. Simultaneously, the MASTER supply voltage (E_{OM}) drives the E_0 SLAVE amplifier (1/2 IC301) which establishes the SLAVE supply voltage (E_{OS}) according to the transfer function $E_{OS} = E_{OM} (R_i/R_f)$, where $R_i = R317$ (20K), $R_f = R318$ (20K). Since the resistance ratio $R_i/R_f = 1$, the SLAVE supply output voltage follows that of the MASTER output voltage in the same ratio. Output voltage variations, caused by changes in a-c input voltage or load conditions, or by an adjustment of the VOLTAGE CONTROL (R103), produce an error signal at the input to the E_0 MASTER voltage mode amplifier (IC303), which is amplified and transmitted via the gate diode (CR327) and protective diode CR325 to the base of the NPN pass transistor (Q601).

The MASTER pass transistor (Q601) changes its collector/emitter potential in response to the amplified error signal in such a way as to correct exactly for the initial voltage variation, while simultaneously the SLAVE section with the E_0 SLAVE amplifier (1/2 IC301) and pass transistor (Q701) performs the identical correction at its output.

- k) **CURRENT LIMIT CIRCUIT ($\pm 20V$, 1A Supply).** The current limit circuit consists of the MASTER supply sensing resistor (R306), the I_O LIMIT MASTER amplifier (1/2 IC302) and the Reference Inverter amplifier (1/2 IC302), The SLAVE supply sensing resistor (R316) and the I_O LIMIT SLAVE amplifier (1/2 IC301). The output current is sampled continuously by the sensing resistors (R306, R316) which develop a sensing voltage across them, proportional to the output current flow. The sensing voltage from each sensing resistor is connected to the inverting input of the respective I_O LIMIT amplifier and is compared to a reference potential, connected to the other input of each I_O LIMIT amplifier. The reference potential (derived from CR323, R336) is applied, via the arm of the I_O LIMIT control to the non-inverting input of the SLAVE I_O LIMIT amplifier, and via the REFERENCE INVERTER (1/2 IC302) to the non-inverting input of the MASTER I_O LIMIT amplifier. The REFERENCE INVERTER has a gain of slightly lower than unity, to insure the control over the current limit by the MASTER supply in a common load application (tracking supply in series). The reference potential can be varied (via the I_O LIMIT CONTROL, R335) to permit the setting of the current limit point from approximately 10% to 110% of the rated output current. As long as the reference potential at the input of the I_O LIMIT amplifier is greater than the sensing voltage from the current sensing resistors (R306, R316) the current limit circuit is inactive. If excessive output current is flowing, however, in either the MASTER or the SLAVE section of the power supply, it will result in a larger sensing voltage than the applied reference potential and the associated I_O LIMIT amplifier will conduct and take control (via its associated gate diode (CR320, CR326) of its PASS TRANSISTOR (Q601, Q701) transferring the MASTER or SLAVE section of the power supply into the current limit mode. In this operating mode, the output current will remain at the limiting value set by the I_O LIMIT control (R335), while the value of the output voltage will be reduced to a value depending on the load resistance (e.g., for a short circuit, the output voltage will be zero).
- l) **AMPLIFIER POWER SUPPLY ($\pm 20V$ SECTION OF MODEL MPS 620M).** This d-c source is derived from a secondary winding on transformer T202. A bridge rectifier (CR307) and a capacitor filter (C302) provide the raw d-c voltage which is stabilized by two zener diodes (CR309, CR310) which are fed from a constant current stage (Q302, CR308 with associated components). This stabilized $\pm 12V$ source provides the operating potential for the operational amplifiers (IC301, 302 and 303). The (-) 12 volt side of the dual source is used to establish the reference potential (CR323, via R332), while R349 loads the (+) 12 volt side to establish equal loading of both sides.

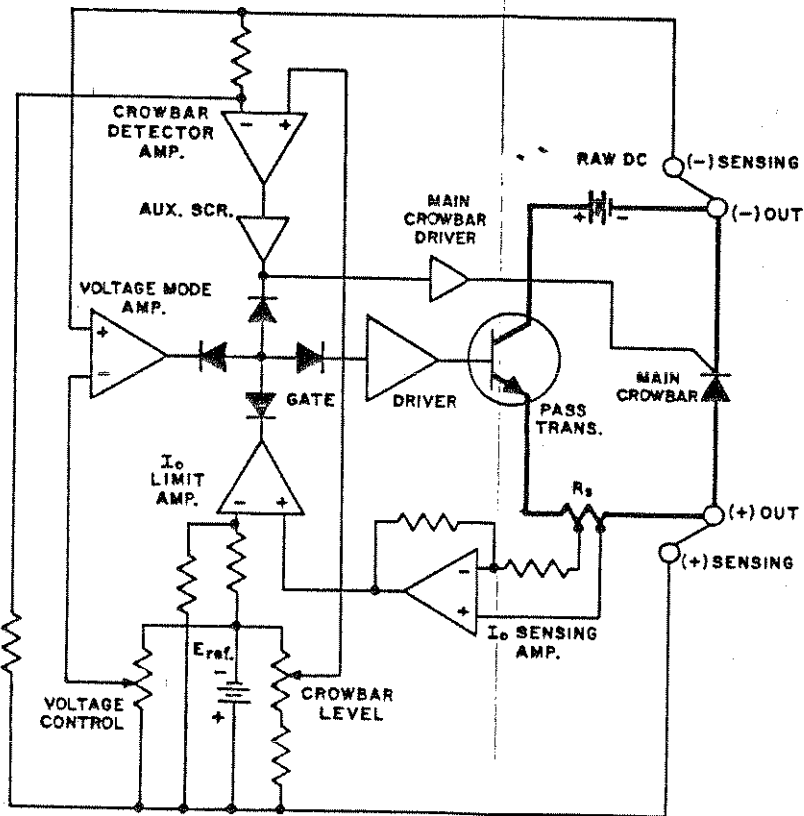

FIG. 4-2 SIMPLIFIED SCHEMATIC DIAGRAM, 6V-5A SUPPLY

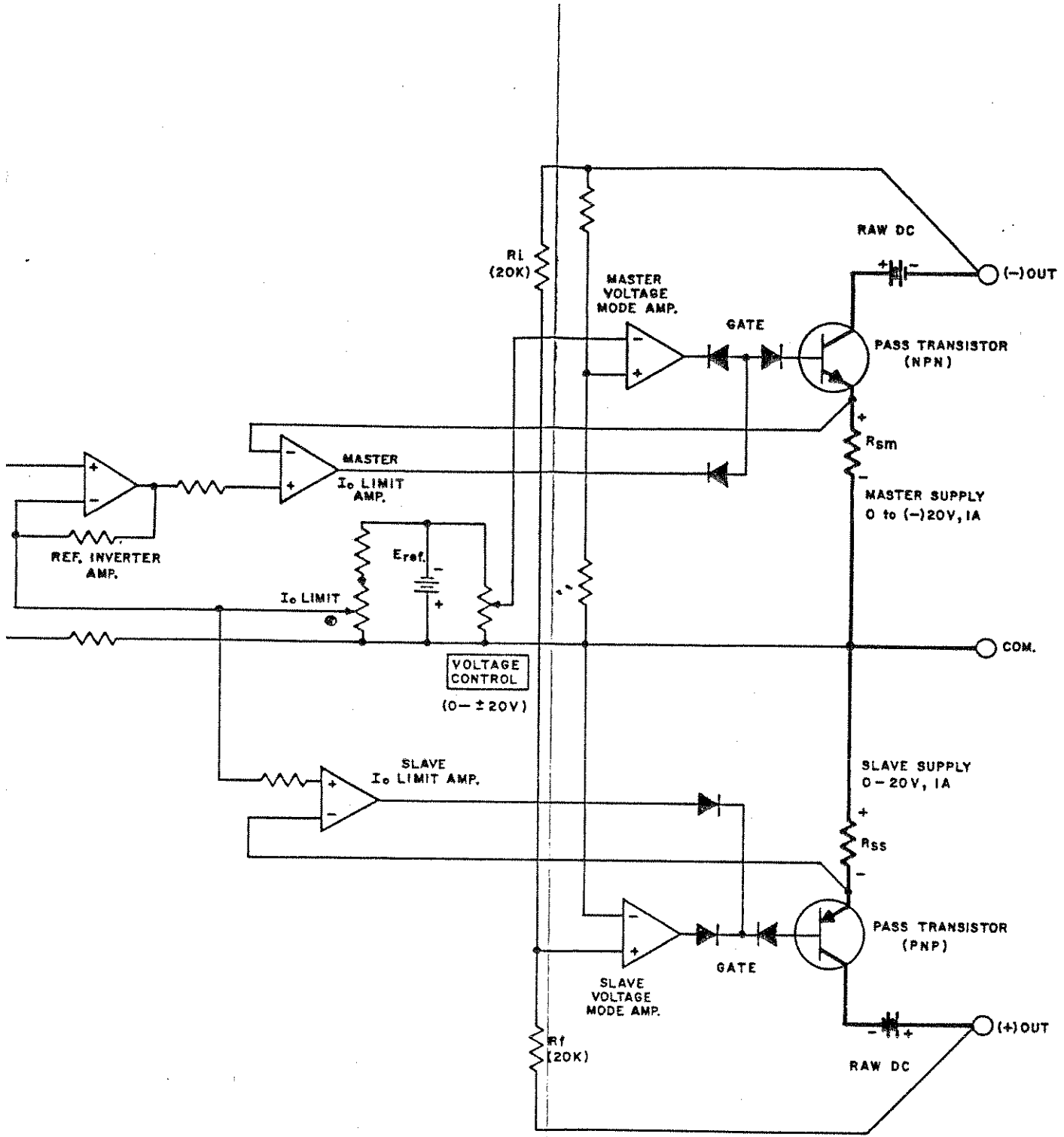

FIG. 4-3 SIMPLIFIED SCHEMATIC DIAGRAM, ±20V, 1A SUPPLY

SECTION V – MAINTENANCE

5-1 GENERAL

- 5-2 This section covers maintenance procedures, troubleshooting notes, calibration and test measurements for the Model MPS 620M.
- 5-3 Conservative rating of all components and the uncongested lay-out should keep maintenance problems at a minimum. If trouble does develop, however, the easily removed wrap-around cover and the plug-in feature of most circuit boards allow quick access to all components of the power supply.

5-4 DISASSEMBLY (Refer to FIG. 5-1)

- a) COVER REMOVAL. The wrap-around cover may be taken off by loosening and removing its (11) holding screws.
- b) PRINTED CIRCUIT BOARD REMOVAL.
- 1) A1 PC BOARD (RIGHT SIDE AS SEEN FROM FRONT). After removing the four (4) holding screws, disconnect the wires attached by means of the "quick-disconnect" terminals and the two (2) side connectors. Lift board from its bottom connector.
 - 2) A3 PC BOARD (LEFT SIDE AS SEEN FROM FRONT). After removing the six (6) holding screws, disconnect the four (4) side connectors and lift board from its bottom connector.
- c) HEAT SINK REMOVAL. Each heat sink assembly is mounted with (2) screws through the chassis bottom. After the screws are taken out, the wires may be removed by means of the "quick-disconnect" terminals.
- d) RE-ASSEMBLY. Re-assembly of all components takes place in reverse order of the above described procedures.

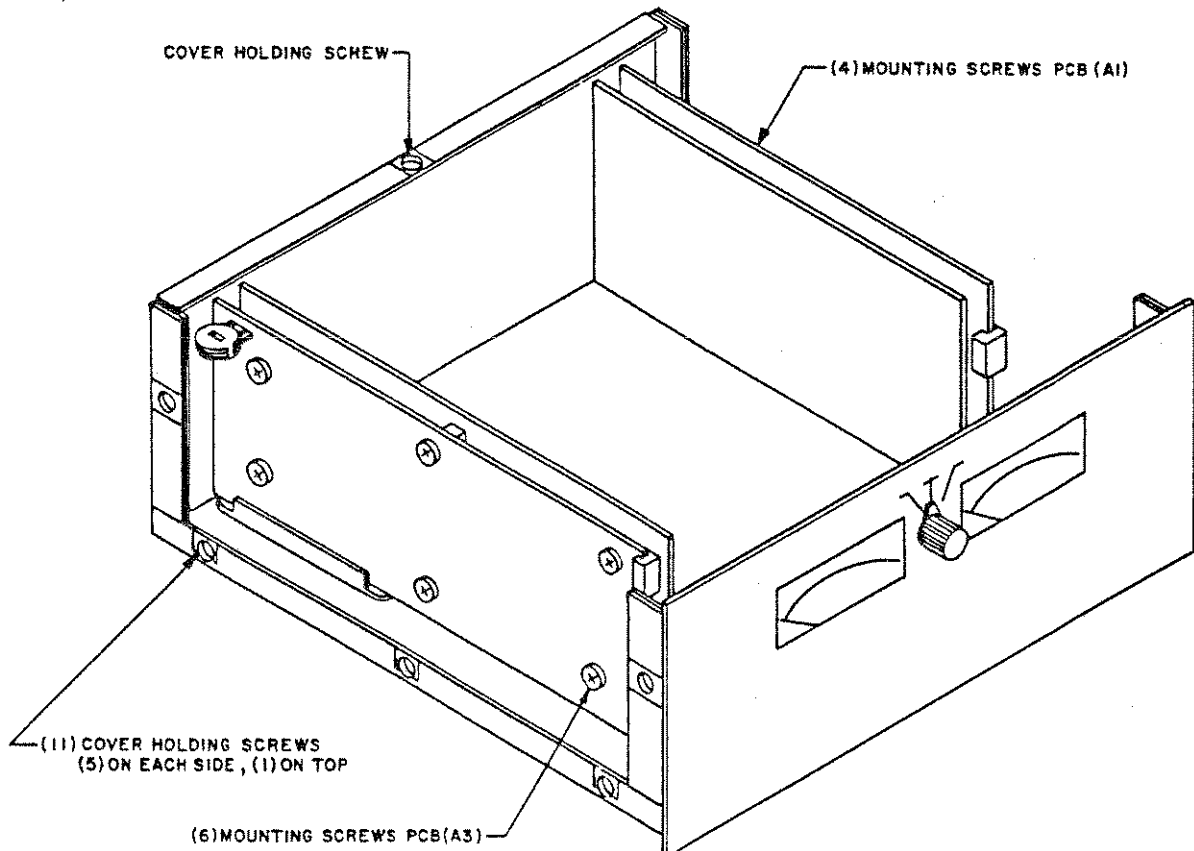

FIG. 5-1 REMOVING THE WRAP-AROUND COVER AND THE PRINTED CIRCUIT BOARDS FROM THE MODEL MPS 620M.

ADJUSTMENT OF THE INTERNAL CURRENT LIMIT ($\pm 20V$, 1A SUPPLY).

The internal current limit point of the ($\pm 20V$, 1A SUPPLY) is factory set at 110% (1.1 ampere). The current limit point can be re-set to any value between 0.1A and 1.1A. A convenient way to make the adjustment is as follows:

- 1) BEFORE turning the a-c power switch of the Model MPS 620M "on", place a short circuit, consisting of a short piece of 18 AWG wire from the COMMON to the (+) 20V output terminal.
- 2) Locate the internal I_O LIMIT control (R335, see Section II, FIG. 2-3 for location) and turn to its maximum counterclockwise position.
- 3) Turn MPS 620M "on" and adjust I_O LIMIT (R335) to the selected limit point, using the front panel ammeter. DO NOT ADJUST THE CONTROL TO HIGHER THAN 1.1 AMPERES. Although this might be possible due to component tolerances, malfunction of the power supply may be caused by exceeding the dissipation rating of the series pass transistors.

TROUBLE SHOOTING

Modern, high performance power supplies have reached a state of sophistication which requires thorough understanding of the problems involved in repairing complex, solid-state circuitry. Servicing beyond simple parts replacements should consequently be attempted only by personnel thoroughly familiar with solid state component techniques and with experience in closed-loop circuitry.

Trouble shooting charts, showing resistance and voltage readings are of very limited usefulness with feedback amplifiers and are not included here. Instead, a detailed circuit description (Section IV), parts location diagrams, simplified functional schematics and a main schematic with all significant voltage readings are presented.

The following basic steps in case of power supply malfunctioning may be found helpful:

- a) NO OUTPUT:
 - 1) If power supply does not function at all, check obvious points first. Check a-c input source connections, a-c input source voltage and frequency. (Normally the power supply is delivered for 115V a-c service.)
 - 2) Check if voltage protector is tripped (6V, 5A SUPPLY) by momentarily interrupting the a-c input source.
 - 3) Check if current control has been inadvertently misadjusted ($\pm 20V$, 1A SUPPLY). Turn current control to its correct setting. See PAR. 5-5.
 - 4) Check if error sensing links are correctly placed. (6V, 5A SUPPLY). Refer to Section III, FIG. 3-3 for Load Connections.
 - 5) Check the mating of all printed circuit connectors with their printed circuit card. See Sect. VI, fig. 6-1.
 - 6) Check indicated voltage readings on the main schematic, check transistors and start circuit analysis with the help of Section IV.
- b) HIGH OUTPUT: Checks number (4), (5), and (6) are also applicable for this condition. In addition, check the following:
 - 1) Test main driver and pass element by connecting a 6V dry battery: (-) battery to (-) output terminal, (+) battery terminal successively to the base of Q501 (6V, 5A SUPPLY) and Q601 ($\pm 20V/1A$ SUPPLY). Connect (+) battery terminal to (+) 20V output and (-) battery terminal to base of Q601 ($\pm 20V/1A$ SUPPLY). (See main schematic and component location diagram.) Observe the result on a voltmeter connected across the output. Functioning driver and pass elements should yield readings of approximately 5.3V and 4.6V, respectively. If *shorted* transistors are suspected, confirm by testing with an ohmmeter from emitter to collector if a transistor tester is not available. Polarity reversal on the meter leads should produce an approximate 1:4 resistance ratio on "good" transistors. Replace only with listed types, if defective. If driver and pass elements are functioning, concentrate on the main amplifier board (A1). Look for burned components and replace if necessary.

c) **POOR PERFORMANCE:**

- 1) Excessive output variations are often due to incorrectly connected loads or faulty measurement techniques. Perform measurements only as directed in PAR. 5-11 and follow the connection diagrams.
 - 2) High frequency oscillations at the output are often due to loads with large inductive or capacitive components and/or long load wires. Tightly twisted load wires of sufficient diameter and kept as short as possible are often the solution to the problem. In extreme cases, decoupling **DIRECTLY AT THE LOAD** with appropriate capacitance should be applied.
 - 3) High ripple at the output or the load may be caused by ground loops or long load wires passing through magnetic fields. Grounding of one side of the output and careful lead dressing are often helpful (refer to Section III, PAR. 3-6) for more signal grounding information.
- d) KEPCO Field Engineering Offices or the KEPCO Application Engineering Department are always available for consultation or direct help in difficult service or applications problems.

5-11 POWER SUPPLY MEASUREMENTS

5-12 Output effect measurements (regulation measurements) in the voltage mode of operation and output ripple measurements are an excellent indication of the power supply's d-c performance and may be performed with a minimum of instrumentation. Since these measurements require special techniques to insure correct results, suggestions for their performance are given below:

- a) Required instrumentation:
 - 1) Constant a-c input source voltage with provisions for "stepping" the voltage over the specified region; a variable autotransformer is generally adequate if it is rated to deliver the input current of the unit under test.
 - 2) Resistive load, variable, and capable of dissipating the full output power of the unit under test, equipped with on/off switch.
 - 3) D-C voltage monitor, differential voltmeter or power supply analyzer.
 - 4) A-C ripple monitor, sensitivity better than 1 mV, Ballantine Model 302C or Hewlett Packard Model 400H.
 - 5) Optional: Oscilloscope, vertical sensitivity better than 1 mV/cm.
- b) The proper location of the instrument leads when measuring output effects in response to a-c input source changes or load variations is of the utmost importance. Improperly placed leads may measure voltage drop due to contact resistance and load current flow and thus lead to incorrect results. FIG. 5-2 (a,b) shows clearly how to employ "4-terminal network techniques" when measuring output effects. The principle is very simple but important: **DO NOT MEASURE VOLTAGE DROPS DUE TO LOAD CURRENT.**
- c) Output effects due to source or load variations in the voltage mode of operation are defined as the amount of output voltage change resulting from a specified change in a-c input source voltage or from a change in load resistance. These output effects can be expressed as an absolute change (ΔE_o) or as a percentage in reference to the total output voltage E_o :

$$\% \text{ Output Effect} = \frac{\Delta E_o}{E_o} (100\%) \quad (\text{Eq. 1}).$$

USE THE TEST SET-UP SHOWN IN FIG. 5-2. Vary the a-c input or the load over the specified limits and note the deviation (ΔE_o) on the instrument (M1). Calculate output effects by means of the equation (Eq. 1) above.

d) RIPPLE: RMS ripple may be monitored on a rms reading instrument connected parallel to the instrument measuring the output effects. Careful wire dressing and shielding, as well as good a-c grounding, are of the utmost importance if valid measurements are expected. An oscilloscope may be used for p-p readings of noise and ripple. An approximate rms reading can be calculated from the p-p reading of the ripple displayed on the oscilloscope, if the reading is divided by three.

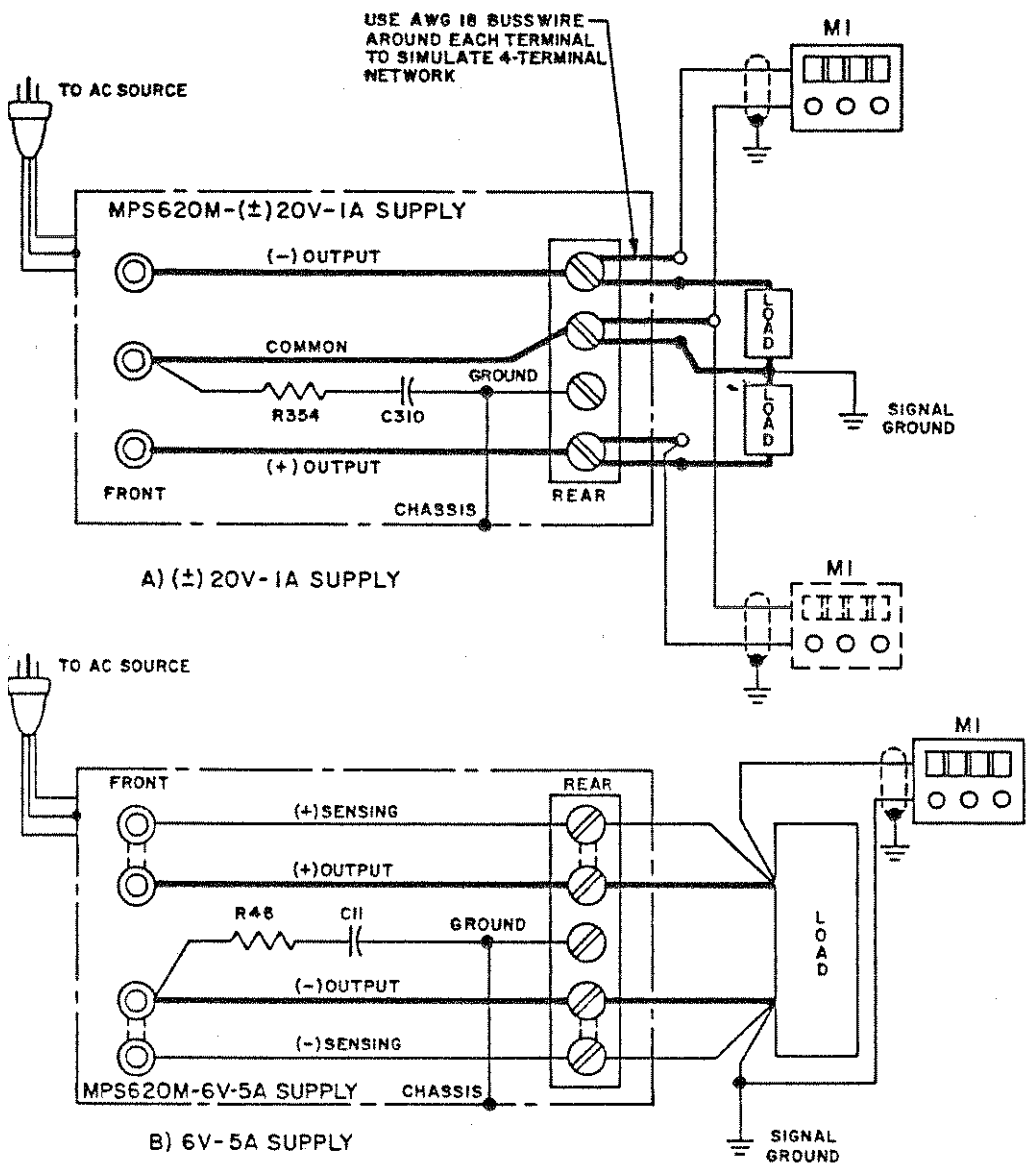

FIG. 5-2 CONNECTIONS FOR OUTPUT EFFECT MEASUREMENTS,
MODEL MPS 620M.

SECTION VI—ELECTRICAL PARTS LIST AND DIAGRAMS

6-1 GENERAL

6-2 This section contains the main schematic, the parts location diagrams, and a list of all replaceable electrical parts. All components are listed in alpha-numerical order of their reference designations. Consult your Kepco Representative for replacement of parts not listed here.

6-3 ORDERING INFORMATION

6-4 To order a replacement part or to inquire about parts not listed in the parts list, address order or inquiry either to your authorized Kepco Sales Representative or to:

KEPCO, INC.
131-38 Sanford Avenue
Flushing, N.Y. 11352

6-5 Specify the following information for each part:

- a) Model and complete serial number of instrument.
- b) Kepco part number.
- c) Circuit reference designator.
- d) Description.

6-6 To order a part not listed in the parts list, give a complete description and include its function and location.

NOTE: KEPKO DOES NOT STOCK OR SELL COMPLETE POWER SUPPLY SUBASSEMBLIES AS DESCRIBED HERE AND ELSEWHERE IN THIS INSTRUCTION MANUAL. SOME OF THE REASONS ARE LISTED BELOW:

- 1) Replacement of a complete subassembly is a comparatively rare necessity.
- 2) Kepco's subassemblies are readily serviceable, since most of them are of the "plug-in" type.
- 3) All active components are socket mounted, making replacement extremely easy.
- 4) The nature of a closed-loop power supply system requires that subassembly replacement is followed by careful measurement of the total power supply performance. In addition, depending on the function of the subassembly, extensive alignment may be required to restore power supply performance to specified values.

IF REPAIRS INVOLVING SUBASSEMBLY REPLACEMENTS ARE REQUIRED, PLEASE CONSULT YOUR LOCAL KEPKO REPRESENTATIVE OR THE KEPKO SALES ENGINEERING DEPARTMENT IN FLUSHING, NEW YORK, N.Y.

ABBREVIATIONS USED IN KEPKO PARTS LISTS

Reference Designators:

= Assembly
 = Blower (Fan)
 = Capacitor
 = Circuit Breaker
 = Diode
 = Device, Signaling (Lamp)
 = Fuse
 = Fuse Holder
 = Integrated Circuit
 = Jack
 = Relay

L = Inductor
 LC = Light-Coupled Device
 M = Meter
 P = Plug
 Q = Transistor
 R = Resistor
 S = Switch
 T = Transformer
 TB = Terminal Block
 V = Vacuum Tube
 X = Socket

A) F

A
 B
 C
 CB
 CR
 DS
 F
 FX
 IC
 J
 K

Descriptive Abbreviations

= Ampere
 = Alternating Current
 = Amplifier
 = Axial
 = Capacitor
 = Ceramic
 = Center-Tap
 = Degree Centigrade
 = Direct Current
 T = Double Pole, Double Throw
 T = Double Pole, Single Throw
 CT = Electrolytic
 = Farad
 I = Polyester Film
 M = Flammable
 = Flame-Proof
 = Degree Fahrenheit
 = Fixed
 = Germanium
 = Henry
 = Hertz
 = Integrated Circuit
 = Kilo (10³)
 = Milli (10⁻³)
 = Mega (10⁶)
 = Manufacturer

MET = Metal
 n = Nano (10⁻⁹)
 NC = Normally Closed
 NO = Normally Open
 p = Pico (10⁻¹²)
 PC = Printed Circuit
 POT = Potentiometer
 PIV = Peak Inverse Voltage
 p-p = Peak to Peak
 ppm = Parts Per Million
 PWR = Power
 RAD = Radial
 RECT = Rectifier
 RECY = Recovery
 REG = Regulated
 RES = Resistor
 RMS = Root Mean Square
 Si = Silicon
 S-End = Single Ended
 SPDT = Single Pole, Double Throw
 SPST = Single Pole, Single Throw
 Stud Mt = Stud Mounted
 TAN = Tantalum
 TSTR = Transistor
 μ = Micro (μ) (10⁻⁶)
 V = Volt
 W = Watt
 WW = Wire Wound

B) D

A
 a-c
 AMF
 AX
 CCR
 CT
 °C
 d-c
 DPD
 DPS
 ELE
 F
 FILM
 FLAI
 FP
 °F
 FXD
 Ge
 H
 Hz
 IC
 K
 m
 M
 MFR



KEPCO. REPLACEMENT PARTS LIST

MODEL MPS 620M PRINTED CIRCUIT BOARD ASS'Y (6V-5A SECTION) A1

Code 9-2076

REFERENCE DESIGNATION	QTY.	DESCRIPTION	MFRS. NAME & PART NO. SEE BOTTOM NOTE	KEPCO PART NO.	REC. SPARE PART QTY.
C1	1	Capacitor,Elect.,Axial Leads 150 μ F, +75 - 10%, 25V	General Electric Type 76F	117-0713	1
C2	1	Capacitor,Elect.,Axial Leads 950 μ F, +150 - 10% 15V	Sangamo Electric Type 052	117-0821	1
C3	1	Capacitor,Elect.,Axial Leads 110 μ F, +75 - 10%, 50V	Sangamo Electric Type 052	117-0641	1
C4	1	Capacitor,Mylar,Axial Leads 0.01 μ F, \pm 20%, 200V	Gudeman Company Type 356	117-0353	1
C5	1	Capacitor,Mylar,Axial Leads 0.001 μ F, \pm 10%, 200V	Sprague Electric Type 192P	117-0570	1
C6	1	Capacitor,Ceramic,Disc. 100 pF, \pm 10%, 500V	Radio Materials Corp. Type JK	117-0754	1
C7	1	Capacitor,Elect.,Axial Leads 22 μ F, \pm 20%, 15V	Sprague Electric Type 30D	117-0444	1
C8	1	Capacitor,Elect.,Axial Leads 150 μ F, +75 - 10%, 15V	Sangamo Electric Type 556	117-0677	1
C9	1	Capacitor,Elect.,Axial Leads 150 μ F, +75 - 10%, 3V	Sangamo Electric Type 556	117-0512	1
C10	1	Capacitor,Elect.,Axial Leads 1000 μ F, +75 - 10%, 20V	Sprague Electric Type 38D	117-0620	1
C11	1	Capacitor,Mylar,Axial Leads 0.1 μ F, \pm 20%, 600V	Wesco Electric Type 33MM	117-0316	1
CR1,2	2	Rectifier,Diode,Axial Leads 100V PIV, 1.5A	Semicon, Inc. SI-1	124-0133	1
CR3,4	2	Rectifier Bridge, Rad. Leads 200V PIV, 1 A	General Inst. Type W-02	124-0346	1
CR5	1	Zener Diode 6.8V \pm 5%, 0.5 W	Motorola 1N5235B	121-0080	1
CR6,9,13, 14,15	5	Switching Diode 75V PIV, 400 mW	American Power Devices 1N4148	124-0437	1
CR7,8	2	Zener Diode 12V \pm 5%, 10 mA	Fairchild Semiconductor 1N963B	121-0058	1
CR10	1	Zener Diode 6.2V \pm 5%, 7.5 mA	International Rectifier 121-0051	121-0051	1
CR16	1	Zener Diode 3.3V \pm 5%, 400 mW	Transitron 1N746A	121-0060	1
CR17	1	Thyristor,SCR 30V, 4 A	RCA S2061Y	124-0471	1
IC1	1	I.C. Operational Amplifier Type 558	Signetics N5558	250-0040	1
IC2,3	2	I.C. Operational Amplifier Type 741	Motorola MC1741P	250-0025	1
Q1	1	Transistor,Silicon,NPN Power, TO-66	RCA 2N3054	119-0060	1
Q2,3	2	Transistor,Silicon,NPN Small Signal, TO-5	RCA 2N3053	119-0059	1

NOTE: REPLACEMENT PARTS MAY BE ORDERED FROM KEPCO, INC. ORDERS SHOULD INCLUDE KEPCO PART NUMBER AND DESCRIPTION.

PLEASE NOTE: THE MANUFACTURER'S NAME AND PART NUMBER LISTED FOR EACH ITEM ON REPLACEMENT PARTS LISTS REPRESENTS AT LEAST ONE SOURCE FOR THAT ITEM AND IS LISTED SOLELY FOR THE CONVENIENCE OF KEPCO EQUIPMENT OWNERS IN OBTAINING REPLACEMENT PARTS LOCALLY. WE RESERVE THE RIGHT TO USE EQUIVALENT ITEMS FROM ALTERNATE SOURCES. KEPCO, INC.



KEPCO. REPLACEMENT PARTS LIST

MODEL MPS 620M PRINTED CIRCUIT BOARD ASS'Y (6V-5A SECTION) A1

Code 3778

REFERENCE DESIGNATION	QTY.	DESCRIPTION	MFRS. NAME & PART NO. SEE BOTTOM NOTE	KEPCO PART NO.	REC. SPARE PART QTY.
Q4	1	Transistor, Silicon, PNP Small Signal, TO-5	Fairchild Semiconductor 2N4355	119-0076	1
Q5	1	Transistor, Silicon, PNP Small Signal, TO-106	Fairchild 2N5138	119-0096	1
R1	1	Resistor, Fixed, Pwr., Axial 500 ohm, 5%, 3 W	Tepro Electric Type TS-3C	115-0459	1
R2	1	Resistor, Fixed, Molded 2 K, 5%, 1/2 W	Allen Bradley EB2025	115-0520	1
R3,47	2	Resistor, Fixed, Molded 100 ohm, 10%, 1/4 W	TRW Type GBT-1/4	115-2231	1
R4	1	Resistor, Fixed, Molded 470 ohm, 10%, 1/4 W	TRW Type GBT-1/4	115-2235	1
R5	1	Resistor, Fixed, Molded 2.2 K, 10%, 1/4 W	Allen Bradley CB2221	115-2382	1
R6,15, 31,46	4	Resistor, Fixed, Molded 10 ohm, 10%, 1/4 W	Allen Bradley CB1001	115-2230	2
R7,44	2	Resistor, Fixed, Molded 560 ohm, 5%, 1/2 W	Allen Bradley EB 5615	115-0888	1
R8	1	Resistor, Fixed, Molded 82 K, 10%, 1/2W	Allen Bradley EB 8231	115-0776	1
R9	1	Resistor, Fixed, Molded 2.7 K, 5%, 1 W	Allen Bradley GB 2725	115-0978	1
R10	1	Resistor, Fixed, Precision, M.F. 137 ohm, 1%, 1/2W	Dale Electric Type MFF-1/2	115-2075	1
R11	1	Resistor, Fixed, Molded 390 ohm, 10%, 1 W	Allen Bradley GB 3911	115-0383	1
R12,13	2	Resistor, Fixed, Pwr., Axial 0.2 ohm, 3%, 5 W	Tepro Electric Type TS-5W	115-2461	1
R16,22,27,28, 29,33,41,42	8	Resistor, Fixed, Molded 1 K, 10%, 1/4 W	TRW Type GBT-1/4	115-2238	3
R17	1	Resistor, Fixed, Molded 1.2 K, 5%, 1/2 W	Allen Bradley EB 1225	115-1167	1
R18	1	Resistor, Fixed, Precision, M.F. 619 ohm, 1%, 1/2W	Dale Electric Type MFF-1/2	115-2080	1
R19,20	2	Resistor, Fixed, Precision, M.F. 6.98 K, 1%, 1/8 W	Dale Electric Type MFF-1/8	115-2449	1
R21	1	Resistor, Fixed, Precision, M.F. 10 K, 1%, 1/8 W	Dale Electric Type MFF-1/8	115-2174	1
R23,26	2	Resistor, Fixed, Precision, M.F. 1 K, 1%, 1/8 W	Dale Electric Type MFF-1/8	115-2180	1
R24	1	Resistor, Fixed, Pwr. Shunt, 4T 0.1 ohm, 1%, 5 W	Tepro Electric Type TSK-5W	115-2538	1
R25	1	Resistor, Fixed, Pwr., Axial 100 ohm, 5%, 3 W	Hardwick Hindle Type 718	115-0471	1
R32	1	Resistor, Fixed, Precision, M.F. 2 K, 1%, 1/8 W	Dale Electric Type MFF-1/8	115-2334	1

NOTE: REPLACEMENT PARTS MAY BE ORDERED FROM KEPCO, INC. ORDERS SHOULD INCLUDE KEPCO PART NUMBER AND DESCRIPTION.

PLEASE NOTE: THE MANUFACTURER'S NAME AND PART NUMBER LISTED FOR EACH ITEM ON REPLACEMENT PARTS LISTS REPRESENTS AT LEAST ONE SOURCE FOR THAT ITEM AND IS LISTED SOLELY FOR THE CONVENIENCE OF KEPCO EQUIPMENT OWNERS IN OBTAINING REPLACEMENT PARTS LOCALLY. WE RESERVE THE RIGHT TO USE EQUIVALENT ITEMS FROM ALTERNATE SOURCES KEPCO, INC



KEPCO. REPLACEMENT PARTS LIST

MODEL MPS 620M PRINTED CIRCUIT BOARD ASS'Y (6V-5A SECTION) A1

Code 3778

REFERENCE DESIGNATION	QTY.	DESCRIPTION	MFRS. NAME & PART NO. SEE BOTTOM NOTE	KEPCO PART NO.	REC. SPARE PART QTY.
R34,40	2	Resistor, Fixed, Precision, M.F. 8.06 K, 1%, 1/8 W	Dale Electric Type MFF-1/8	115-2445	1
R35	1	Resistor, Fixed, Molded 10 K, 10%, 1/4W	TRW Type GBT-1/4	115-2211	1
R37	1	Resistor, Fixed, Precision, M.F. 8.66 K, 1%, 1/8 W	Dale Electric Type MFF-1/8	115-2511	1
R38	1	Resistor, Fixed, Precision, M.F. 2.74 K, 1%, 1/8 W	Dale Electric Type MFF-1/8	115-2439	1
R39	1	Resistor, Fixed, Molded 1.5 K, 10%, 1/4 W	Allen Bradley CB 1521	115-2229	1
R43	1	Resistor, Fixed, Molded 1 K, 10%, 1/2 W	Allen Bradley EB 1021	115-0547	1
R45	1	Resistor, Fixed, Molded 220 ohm, 10%, 1 W	Allen Bradley GB 2211	115-0631	1
R48,49	2	Resistor, Fixed, Molded 22 K ohm, 10%, 1/4 W	IRC GBT-1/4	115-2458	1

NOTE: REPLACEMENT PARTS MAY BE ORDERED FROM KEPCO, INC. ORDERS SHOULD INCLUDE KEPCO PART NUMBER AND DESCRIPTION.

PLEASE NOTE: THE MANUFACTURER'S NAME AND PART NUMBER LISTED FOR EACH ITEM ON REPLACEMENT PARTS LISTS REPRESENTS AT LEAST ONE SOURCE FOR THAT ITEM AND IS LISTED SOLELY FOR THE CONVENIENCE OF KEPCO EQUIPMENT OWNERS IN OBTAINING REPLACEMENT PARTS LOCALLY. WE RESERVE THE RIGHT TO USE EQUIVALENT ITEMS FROM ALTERNATE SOURCES. KEPCO, INC.



KEPCO. REPLACEMENT PARTS LIST

MODEL MPS 620M MAIN CHASSIS ASSEMBLY (A2) WITH FRONT PANEL

Code 9-2076

REFERENCE DESIGNATION	QTY.	DESCRIPTION	MFRS. NAME & PART NO. SEE BOTTOM NOTE	KEPCO PART NO.	REC. SPARE PART QTY.
-----------------------	------	-------------	--	----------------	----------------------

FRONT PANEL ASSEMBLY CONTAINS:

CR101	1	Rectifier, Diode, Axial Leads Double Diced (Special)	Semicon, Inc. Type HVP	124-0178	1
CR102	1	Thyristor, SCR, Stud 100V PIV, 16A	International Rectifier Type IR30A	124-0267	1
CR103	1	Rectifier, Diode, Stud 100V PIV, 15 A	International Rectifier Type 40HF10	124-0335	1
DS101	1	LED Indicator	Littlefuse 971-660X-02WRN	152-0096	1
M101	1	Voltmeter, Dual Scale 0-7, 0-21V d-c	Beede Type QAW 25	135-0508	0
M102	1	Ammeter, Dual Scale 0-1, 0-5 A d-c	Beede Type QAW 25	135-0507	0
R101,103	2	Resistor, Variable, Multiturn 7 K, 5%, 2 W	Bourns, Inc. Type 3509	115-1257	1
R102	1	Resistor, Variable, Cermet 10 K, 10%, 2 W	Bourns, Inc. 3852E-16-2-103A	115-2612	1
R104	1	Resistor, Fixed, Molded 330 ohm, 10%, 1/4 W	Allen Bradley CB 3311	115-2233	1
RC101	1	R-C Network 0.1 μ F, \pm 20%, 400V and 100 ohm, 10%, 1/2 W	Sprague Electric Type 288P	245-0003	1
S102	1	Switch, Rotary 4 Pole, 3 Position	Stackpole 73-1049	127-0328	1
SDS101	1	Toggle-Paddle Switch SPST, Illum.	Carling Switch 127-0322	127-0322	0

MAIN CHASSIS ASSEMBLY CONTAINS:

C201	1	Capacitor, Ceramic, Disc. 0.05 μ F, \pm 20%, 500V	Sprague Electric Type 36C	117-0163	1
C202	1	Capacitor, Elect., Can 10 K μ F, +75 - 10%, 20V	General Electric Type 88F	117-0858	1
CR201,202	2	Rectifier, Diode, Stud 100V PIV, 16A	Syntron R2010	124-0485	1
F201	1	Fuse, Slow Blow 2.5 A/125V	Bussman Type MDL	141-0029	5
F202	1	Fuse, Instantaneous 6 A/250V	Bussman Type MTH	141-0001	5
R201	1	Resistor, Fixed, Molded 220 ohm, 5%, 2 W	Allen Bradley HB 2215	115-2114	1
T201	1	Transformer, Power (6V)	Kepeco Magnetics 100-2065	100-2065	1
T202	1	Transformer, Power (20V)	Kepeco Magnetics 100-2066	100-2066	1

NOTE: REPLACEMENT PARTS MAY BE ORDERED FROM KEPCO, INC. ORDERS SHOULD INCLUDE KEPCO PART NUMBER AND DESCRIPTION.

PLEASE NOTE: THE MANUFACTURER'S NAME AND PART NUMBER LISTED FOR EACH ITEM ON REPLACEMENT PARTS LISTS REPRESENTS AT LEAST ONE SOURCE FOR THAT ITEM AND IS LISTED SOLELY FOR THE CONVENIENCE OF KEPCO EQUIPMENT OWNERS IN OBTAINING REPLACEMENT PARTS LOCALLY. WE RESERVE THE RIGHT TO USE EQUIVALENT ITEMS FROM ALTERNATE SOURCES.	KEPCO, INC.
---	-------------



KEPCO. REPLACEMENT PARTS LIST

MODEL MPS 620M PRINTED CIRCUIT ASS'Y (±20V - 1 A SECTION) A3

Code 3378

REFERENCE DESIGNATION	QTY.	DESCRIPTION	MFRS. NAME & PART NO. SEE BOTTOM NOTE	KEPCO PART NO.	REC. SPARE PART QTY.
C301,303	2	Capacitor, Elect., Axial Lds. 1500 μ F, +75, 50V	General Electric Type 84F	117-0857	1
C302	1	Capacitor, Elect., Axial Lds. 110 μ F, +75 -10%, 50V	Sangamo Electric Type 052	117-0641	1
C304,309	2	Capacitor, Mylar, Axial Lds. 0.2 μ F, ±10%, 200V	Industrial Condenser 2LUMZ20	117-0236	1
C305,308	2	Capacitor, Mylar, Axial Lds. 0.001 μ F, ±10%, 200V	Sprague Electric Type 192P	117-0570	1
C306,307	2	Capacitor, Mylar, Axial Lds. 0.01 μ F, ±20%, 200V	Gudeman Company Type 356	117-0353	1
C310	1	Capacitor, Mylar, Axial Lds. 0.01 μ F, ±20%, 600V	Wesco Electric Type 33MM	117-0316	1
C311,312	2	Capacitor, Elect., Axial Lds. 200 μ F, +75 -10%, 50V	Sangamo Electric Type 052	117-0651	1
CR301-306, 311-316, 329,330	14	Rectifier, Diode, Axial Lds. 100V PIV, 1.5 A	Semicon, Inc. SI-1	124-0344	1
CR307	1	Rectifier Bridge, Rad. Lds. 200V PIV, 1 A	General Instrument Type W-02	124-0346	1
CR308	1	Zener Diode 6.8V ±5%, 0.5 W	Motorola 1N5235B	121-0080	1
CR309,310, 322,324,328	5	Zener Diode 12V ±5%, 10 mA	Fairchild Semiconductor 1N963B	121-0058	1
CR317-321, 325-327, 331,332	10	Switching Diode 75V PIV, 400 mW	American Power Devices 1N4148	124-0437	1
CR323	1	Zener Diode 5.6-6.2V, 7.5 mA	International Rectifier 1N821	121-0041	1
IC301,302	2	I.C. Operational Amplifier Type 558	Signetics N5558	250-0040	1
IC303	1	I.C. Operational Amplifier Type 741	Motorola MC1741P	250-0025	1
Q301,302	2	Transistor, Silicon, NPN Small Signal, TO-5	RCA 2N3053	119-0059	1
Q303	1	Transistor, Silicon, PNP Small Signal, TO-5	RCA 2N4036	119-0074	1
R301,311	2	Resistor, Fixed, Molded 39 ohm, 5%, 1/2 W	Allen Bradley EB3905	115-1242	1
R302,312	2	Resistor, Fixed, Pwr., Axial 2 K, 5%, 3 W	Tepro Electric Type TS-3W	115-0747	1
R321,328, 339,347,354	5	Resistor, Fixed, Molded 10 ohm, 10%, 1/4 W	Allen Bradley CB 1001	115-2230	3
R304,315	2	Resistor, Fixed, Pwr., Axial 500 ohm, 5%, 3 W	Tepro Electric Type TS-3C	115-0459	1
R305,313	2	Resistor, Fixed, Pwr., Axial 1 K, 5%, 3 W	Tepro Electric Type TS-3C	115-1302	1

NOTE: REPLACEMENT PARTS MAY BE ORDERED FROM KEPCO, INC. ORDERS SHOULD INCLUDE KEPCO PART NUMBER AND DESCRIPTION.

PLEASE NOTE: THE MANUFACTURER'S NAME AND PART NUMBER LISTED FOR EACH ITEM ON REPLACEMENT PARTS LISTS REPRESENTS AT LEAST ONE SOURCE FOR THAT ITEM AND IS LISTED SOLELY FOR THE CONVENIENCE OF KEPCO EQUIPMENT OWNERS IN OBTAINING REPLACEMENT PARTS LOCALLY. WE RESERVE THE RIGHT TO USE EQUIVALENT ITEMS FROM ALTERNATE SOURCES. KEPCO, INC.



KEPCO. REPLACEMENT PARTS LIST

MODEL MPS 620M PRINTED CIRCUIT BOARD ASS'Y (±20V-1 A SECTION) A3

Code 9-2076

REFERENCE DESIGNATION	QTY.	DESCRIPTION	MFRS. NAME & PART NO. SEE BOTTOM NOTE	KEPCO PART NO.	REC. SPARE PART QTY.
R306,316	2	Resistor,Fixed,Pwr.,Axial 0.5 ohm, 1%, 3 W	Tepro Electric Type TS-3W	115-2220	1
R307	1	Resistor,Fixed,Molded 82 K, 10%, 1/2 W	Allen Bradley EB 8231	115-0776	1
R308	1	Resistor,Fixed,Molded 2.7 K, 5%, 1 W	Allen Bradley GB 2725	115-0978	1
R309	1	Resistor,Fixed,Precision,M.F. 137 ohm, 1%, 1/2 W	Dale Electric Type MFF-1/2	115-2075	1
R310	1	Resistor,Fixed,Molded 390 ohm, 10%, 1 W	Allen Bradley GB 3911	115-0383	1
R317,318,352	3	Resistor,Fixed,Precision,M.F. 20 K, 1%, 1/2 W	IRC Type CEC	115-2039	1
R319,320,329, 331,337,338, 348,353	8	Resistor,Fixed,Molded 1 K, 10%, 1/4 W	TRW Type GBT-1/4	115-2238	3
R323,327, 340,344	4	Resistor,Fixed,Molded 220 ohm, 10%, 1/4 W	Allen Bradley CB 2211	115-2227	2
R325,342	2	Resistor,Fixed,Molded 2.4 K, 5%, 1/2 W	Allen Bradley EB 2425	115-0795	1
R330	1	Resistor,Fixed,Precision,M.F. 21 K, 1%, 1/8 W	Dale Electric Type MFF-1/8	115-2298	1
R332	1	Resistor,Fixed,Precision,M.F. 619 ohm, 1%, 1/2 W	Dale Electric Type MFF-1/2	115-2080	1
R333	1	Resistor,Fixed,Precision,M.F. 1 K, 1%, 1/8 W	Dale Electric Type MFF-1/8	115-2180	1
R334	1	Resistor,Fixed,Precision,M.F. 960 ohm, 1%, 1/8 W	Dale Electric Type MFF-1/8	115-2479	1
R335	1	Resistor,Variable,Cermet,1-turn 1.5 K, 30%, 1/8 W	CTS Corp. X201 Series	115-1939	1
R336	1	Resistor,Fixed,Molded 4.7 K, 5%, 1/2 W	Allen Bradley EB 4725	115-0350	1
R345,351	2	Resistor,Fixed,Precision,M.F. 8.06 K, 1%, 1/8 W	Dale Electric Type MFF-1/8	115-2445	1
R346	1	Resistor,Fixed,Precision,M.F. 2 K, 1%, 1/8 W	Dale Electric Type MFF-1/8	115-2334	1
R349	1	Resistor,Fixed,Molded 1.2 K, 10%, 1/2 W	Allen Bradley EB 1225	115-1167	1
S301	1	Slide Switch DPDT	Switchcraft 46206 LEH	127-0294	0

NOTE: REPLACEMENT PARTS MAY BE ORDERED FROM KEPCO, INC. ORDERS SHOULD INCLUDE KEPCO PART NUMBER AND DESCRIPTION.

PLEASE NOTE: THE MANUFACTURER'S NAME AND PART NUMBER LISTED FOR EACH ITEM ON REPLACEMENT PARTS LISTS REPRESENTS AT LEAST ONE SOURCE FOR THAT ITEM AND IS LISTED SOLELY FOR THE CONVENIENCE OF KEPCO EQUIPMENT OWNERS IN OBTAINING REPLACEMENT PARTS LOCALLY. WE RESERVE THE RIGHT TO USE EQUIVALENT ITEMS FROM ALTERNATE SOURCES. KEPCO, INC.



KEPCO. REPLACEMENT PARTS LIST

MODEL MPS 620M PASS ASSEMBLY (A4)

Code 9-2076

REFERENCE DESIGNATION	QTY.	DESCRIPTION	MFRS. NAME & PART NO. SEE BOTTOM NOTE	KEPCO PART NO.	REC. SPARE PART QTY.
Q401	1	Transistor,Silicon,NPN Power,TO-3	RCA 2N3054	119-0061	1

PASS ASSEMBLY (A5)

Q501	1	Transistor,Silicon,NPN Power,TO-3	RCA 2N3054	119-0061	1
------	---	--------------------------------------	---------------	----------	---

PASS ASSEMBLY (A6)

Q601	1	Transistor,Silicon,NPN Power,Darlington	Motorola 2N6576	119-0122	1
------	---	--	--------------------	----------	---

PASS ASSEMBLY (A7)

Q701	1	Transistor,Silicon,PNP Power,Darlington	Motorola 2N6051	119-0123	1
------	---	--	--------------------	----------	---

MISCELLANEOUS

TB1	1	Barrier Strip (5-term)	Magnum Electric 206105-00-NL	167-0824	0
TB301	1	Barrier Strip (4-term)	Magnum Electric 206104-00-NL	167-0823	0
P201	1	Input Source Receptacle	Switchcraft, Inc. No. EAC-301	143-0278	1
	1	Fuse holder	Littlefuse No. 342003	150-0001	0
	4	Rubber Feet	Kepeco, Inc. 105-0054	105-0054	-
	1	Carrying Handle Assembly	Philadelphia Handle Co., Inc. No. 7840-7720-451	139-0221	-
	2	Plastic Feet	Kepeco, Inc. 158-0003	158-0003	-
	1	Bail (7")	Kepeco, Inc. 139-0220	139-0220	-
	1	Plastic Foot (Bail Left)	Kepeco, Inc. 158-0005	158-0005	-
	1	Plastic Foot (Bail Right)	Kepeco, Inc. 158-0006	158-0006	-
	3	Binding Post (Red)	Superior Type DF21	151-0041	-
	3	Binding Post (Black)	Superior Type DF21	151-0042	-
	1	Binding Post (Green)	Superior Type DF21	151-0044	-

NOTE: REPLACEMENT PARTS MAY BE ORDERED FROM KEPCO, INC. ORDERS SHOULD INCLUDE KEPCO PART NUMBER AND DESCRIPTION.

PLEASE NOTE: THE MANUFACTURER'S NAME AND PART NUMBER LISTED FOR EACH ITEM ON REPLACEMENT PARTS LISTS REPRESENTS AT LEAST ONE SOURCE FOR THAT ITEM AND IS LISTED SOLELY FOR THE CONVENIENCE OF KEPCO EQUIPMENT OWNERS IN OBTAINING REPLACEMENT PARTS LOCALLY. WE RESERVE THE RIGHT TO USE EQUIVALENT ITEMS FROM ALTERNATE SOURCES KEPCO, INC.



KEPCO. REPLACEMENT PARTS LIST

MODEL MPS 620M MISCELLANEOUS

Code 9-2076

REFERENCE DESIGNATION	QTY.	DESCRIPTION	MFRS. NAME & PART NO. SEE BOTTOM NOTE	KEPCO PART NO.	REC. SPARE PART QTY.
	1	Binding Post (Blue)	Superior Type DF21	151-0045	—
	2	Control Knobs, Black	Buckeye Stamping Co. Type SS-70	155-0056	—
	1	Selector Knob, Gray	Buckeye Stamping Co. Type SS-70	155-0055	—
	1	Cover	Keppo, Inc. 129-0156	129-0156	—
	1	Line Cord	Switchcraft, Inc. No. P2392	118-0552	—

NOTE: REPLACEMENT PARTS MAY BE ORDERED FROM KEPCO, INC. ORDERS SHOULD INCLUDE KEPCO PART NUMBER AND DESCRIPTION.

PLEASE NOTE: THE MANUFACTURER'S NAME AND PART NUMBER LISTED FOR EACH ITEM ON REPLACEMENT PARTS LISTS REPRESENTS AT LEAST ONE SOURCE FOR THAT ITEM AND IS LISTED SOLELY FOR THE CONVENIENCE OF KEPCO EQUIPMENT OWNERS IN OBTAINING REPLACEMENT PARTS LOCALLY. WE RESERVE THE RIGHT TO USE EQUIVALENT ITEMS FROM ALTERNATE SOURCES. KEPCO, INC.

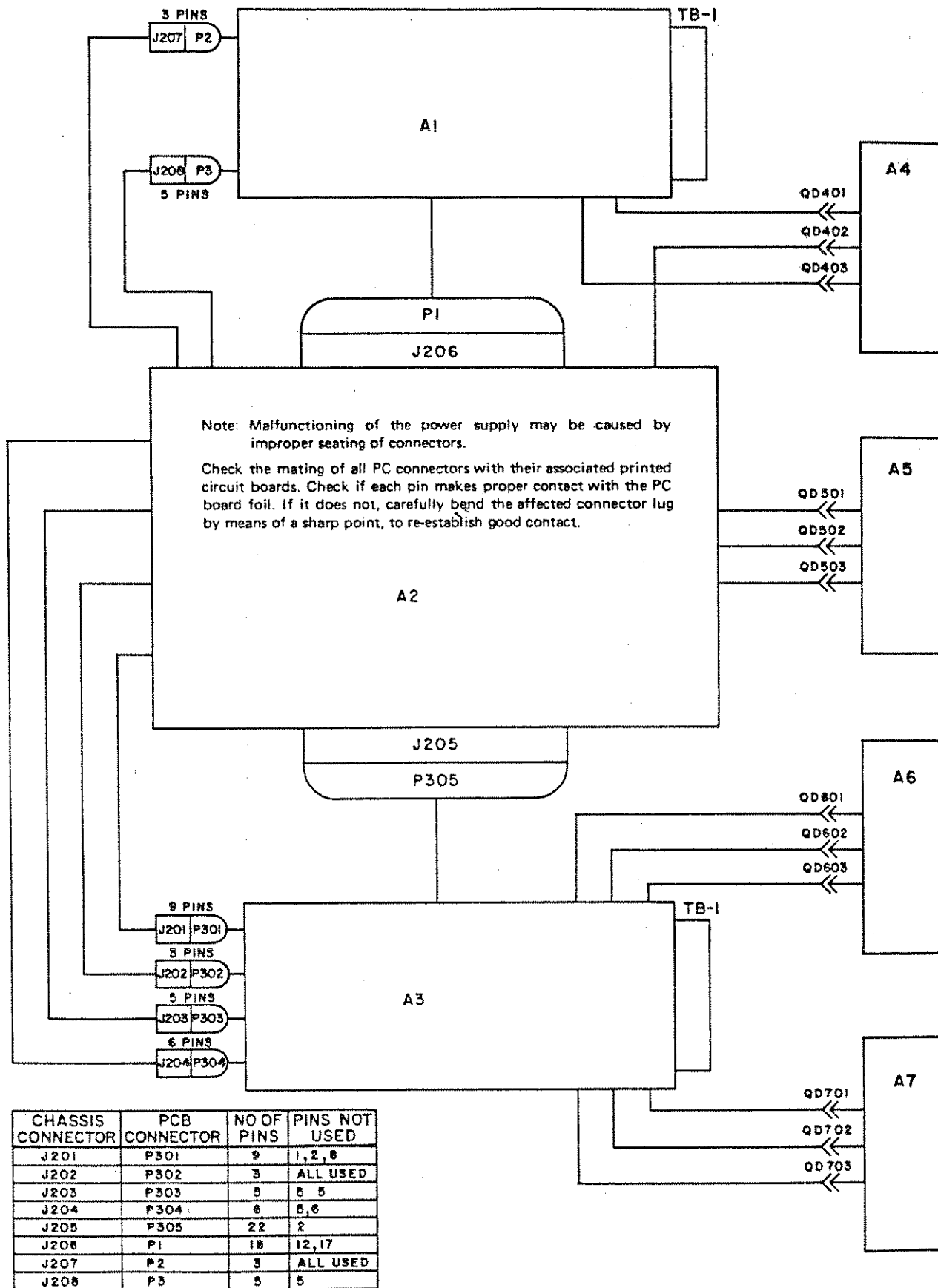

FIG. 6-1 PLUG-IN DIAGRAM, MODEL MPS-620M

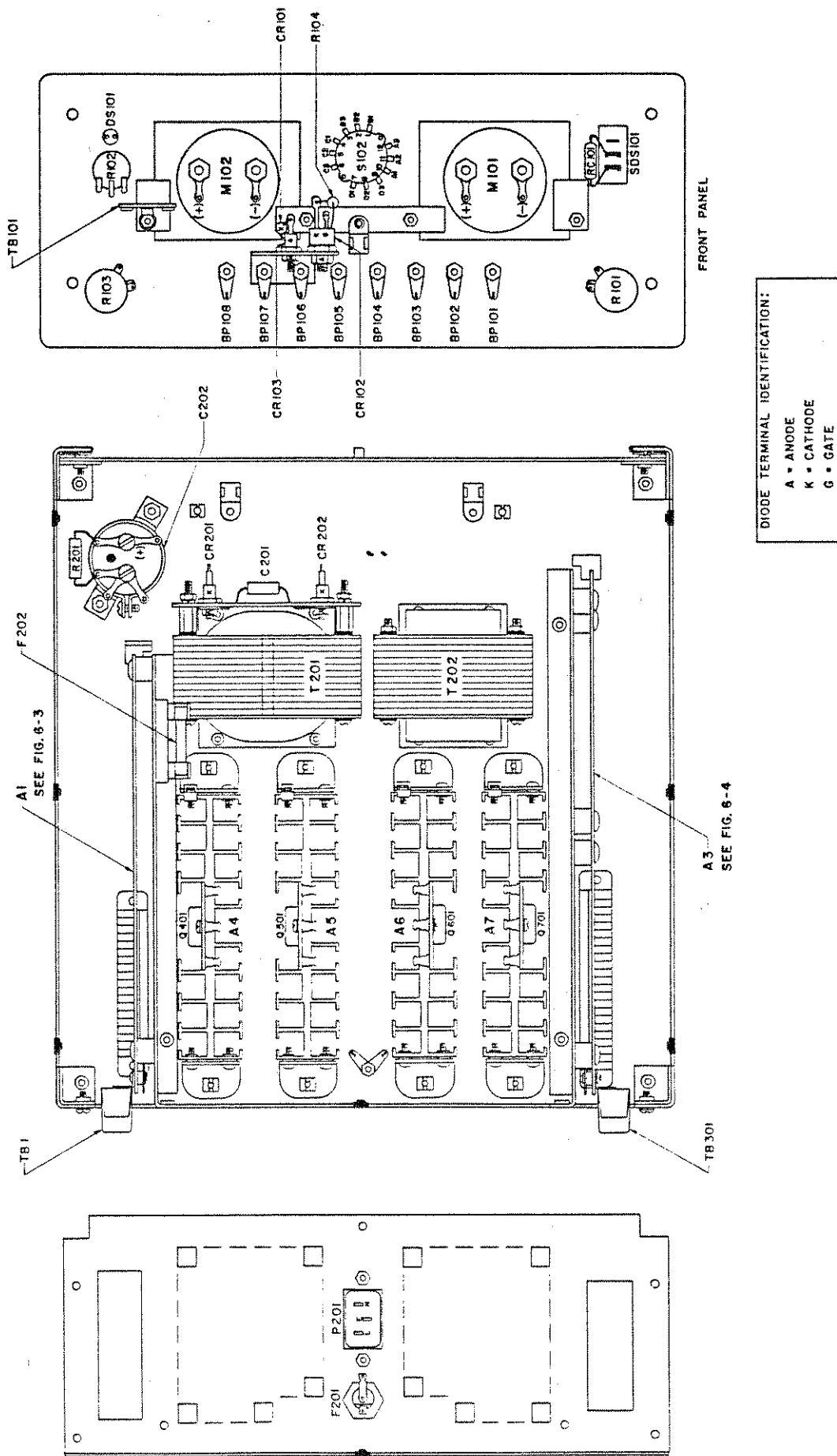

FIG. 6-2 COMPONENT LOCATION, MAIN CHASSIS

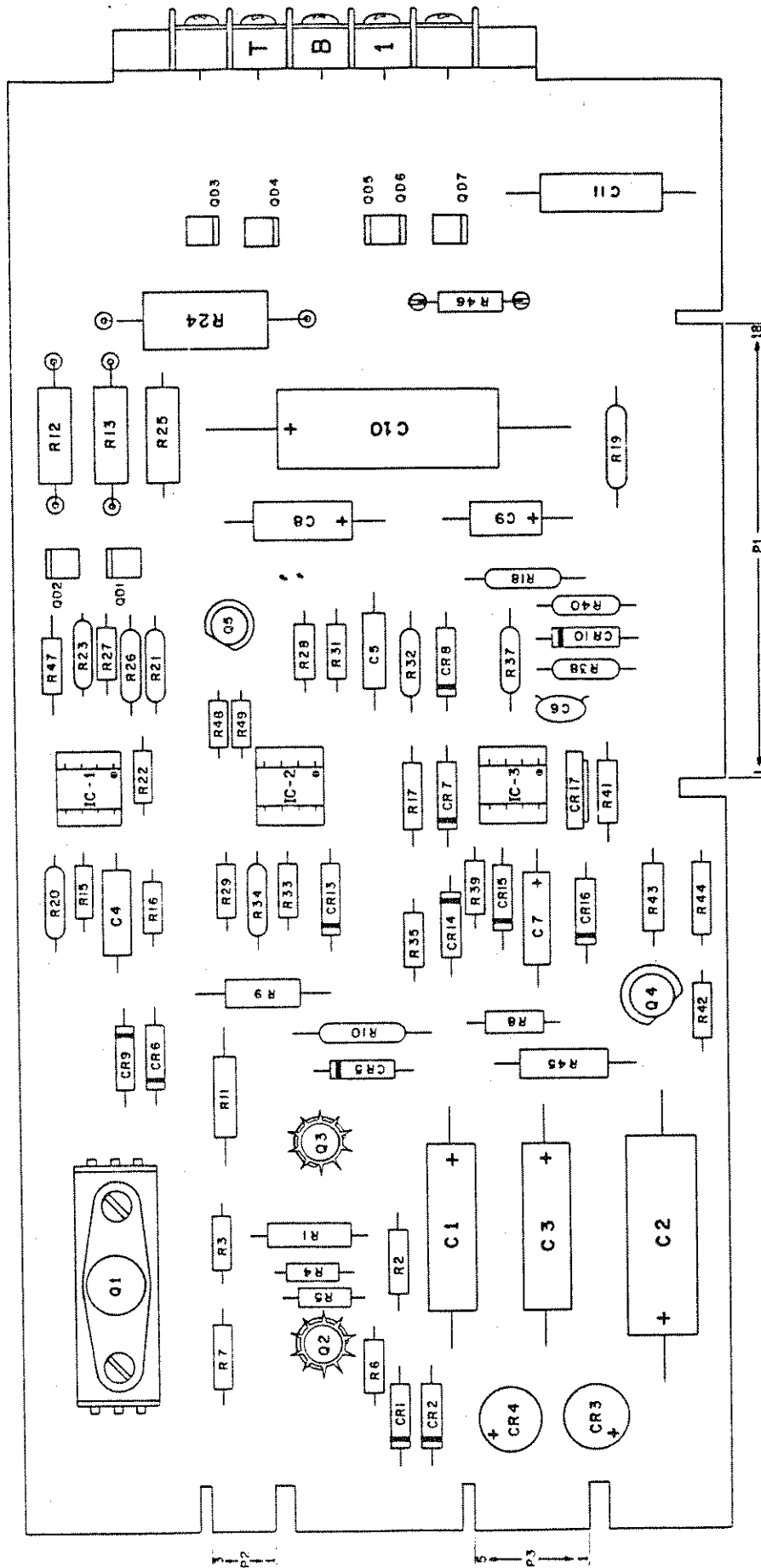

FIG. 6-3 COMPONENT LOCATION, ASSEMBLY A1.

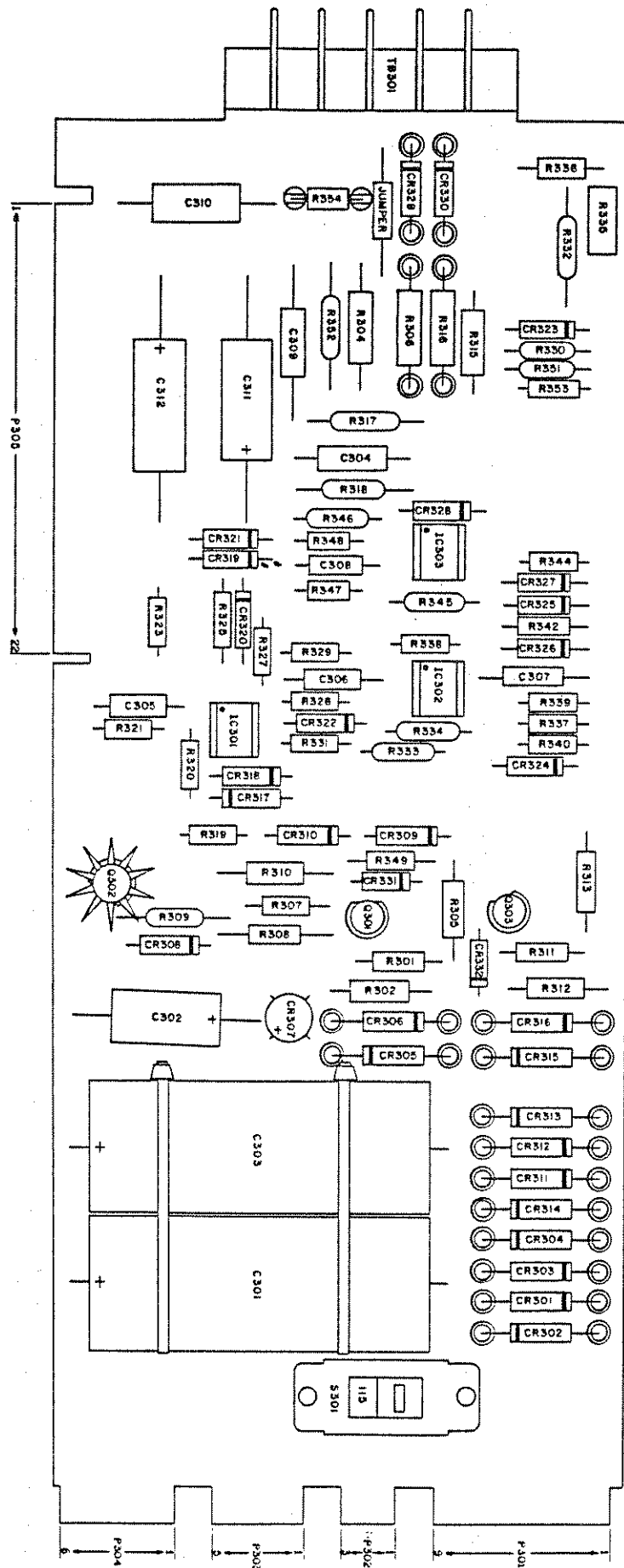

FIG. 6-4 COMPONENT LOCATION, ASSEMBLY A3.

C

C

C

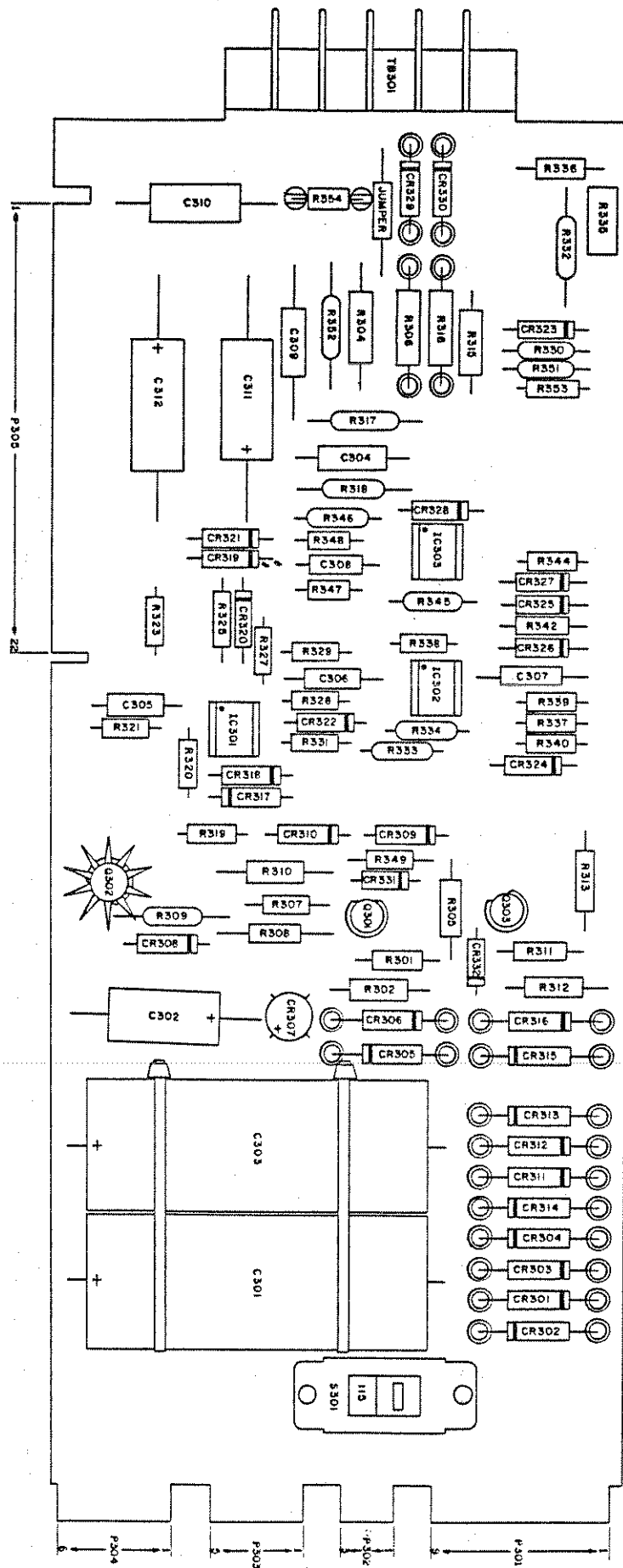

FIG. 6-4 COMPONENT LOCATION, ASSEMBLY A3.